



Air curtains



Contents

Introduction	3
Comfort air curtains C1	4
Basic features	4
Sizes and arrangements	5
Heating outputs	6
Technical parameters	7
Comfort air curtains D2	9
Basic features	9
Sizes and arrangements	10
Heating outputs	11
Technical parameters	12
Control and accessories	14
Control	14
Accessories	16
Functions and settings	18



*Print and language mistakes reserved.
Right for changes reserved.
Date of issue: 13. 3. 2008*

Introduction

Basic features

Doormaster air curtains form an unobtrusive aerodynamic barrier in order to suppress the free flow of air between an inside and outside environment, at the entrance to a building for example. A second integral function of the curtain is the mixing of the air that remains after entering with the air that has been heated in the room where the curtain is installed, which reduces the negative feeling evoked by the flow of cool air. When the curtain has been properly designed, it increases the comfort inside and, at the same time, reduces the operating costs for the building. Doormaster Air Curtains are intended for installation inside in a dry environment and for mounting in a horizontal position above the intake opening. The curtain operates in air void of coarse

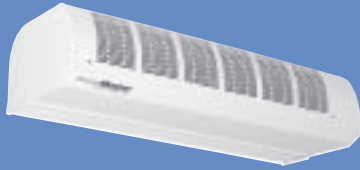
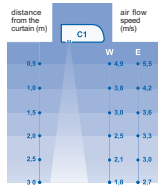
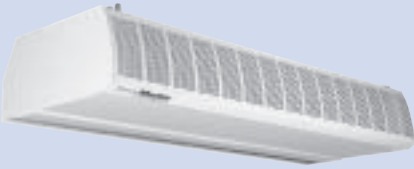
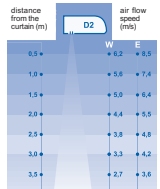
dust particles, greases, chemical vapors and other contaminants. The curtain is intended for an environment with a normal influence classification in accordance with the Czech norm ČSN 33 2000-3, IEC 364-3/A1. Its use is prohibited in an aggressive environment, outdoors, in a moist environment with the danger of condensation or in an environment with a dangerous explosion! The version with electric heating and the version without heating can be operated even at temperatures as low as -5°C (under the condition that there is no condensation in the environment). The version with a water exchanger (W) is not safeguarded by anti-freeze protection and must be installed in a non-freezing environment (+5°C to +40°C). Otherwise it is necessary to ensure a sufficient supply of heated water so that the medium in the water exchanger does not freeze.

Comfort curtains DoorMaster	C1 series		<p>Length of curtain</p> <p>1 m <input type="checkbox"/></p> <p>1,5 m <input type="checkbox"/></p> <p>2 m <input type="checkbox"/></p> <p>Recommended height for installation: 2,2 až 2,5 m*</p>	 <p>At 20°C of air temperature</p>	<ul style="list-style-type: none"> <input type="checkbox"/> Modern design <input type="checkbox"/> Quiet operation <input type="checkbox"/> High efficiency <input type="checkbox"/> Low operational and maintenance costs
	D2 series		<p>Length of curtain</p> <p>1 m <input type="checkbox"/></p> <p>1,5 m <input type="checkbox"/></p> <p>2 m <input type="checkbox"/></p> <p>2,5 m <input type="checkbox"/></p> <p>Recommended height for installation: 2,4 až 3,0 m*</p>	 <p>At 20°C of air temperature</p>	<ul style="list-style-type: none"> <input type="checkbox"/> Low weight <input type="checkbox"/> Easy control <input type="checkbox"/> Long service life <input type="checkbox"/> Favorable price
Industrial Curtains DoorMaster	P series		<p>Length of curtain</p> <p>2 m <input type="checkbox"/></p> <p>2,5 m <input type="checkbox"/></p> <p>3 m <input type="checkbox"/></p> <p>3,5 m <input type="checkbox"/></p> <p>4 m <input type="checkbox"/></p> <p>Installation with reach from 2,0 till 4,5 m*</p>		<ul style="list-style-type: none"> <input type="checkbox"/> Savings on energy <input type="checkbox"/> Low price <input type="checkbox"/> Low operational and maintenance costs <input type="checkbox"/> High efficiency <input type="checkbox"/> Long service life <input type="checkbox"/> Easy control <input type="checkbox"/> Possibility of using in a vertical position <input type="checkbox"/> Short delivery time

* With regard to the suitability of using a given type of curtain in a particular environment, we recommend that you consult with the manufacturer or with a designer of air-handling equipment.

Basic information

Usage

DoorMaster curtains of the C1 series are intended for inside installation above an entrance door. The maximum installation height recommended is 2.5 m. Due to their construction, they are designed for smaller areas where there is frequent movement of people. Their modern design enables them to be used in architecturally demanding structures. Typical places for their installation are administration buildings, stores, hotels, restaurants, banks, hospitals, post offices, gasoline stations etc.

Description of construction

The covering panels are made of lacquered sheet metal and fastened to a frameless construction. The sidewalls are laminated. The basic version comes in the color shade of RAL 9002. The internal components are from leading European manufacturers. Special tangential fans ensure quiet running and low-energy operation. Over-all protection for the covered curtain is IP 20. The fans are furnished with motors that have a temperature insulation for windings of the F class.

Manner of hanging

C1 curtains are hung on M8 hanging rods behind a hanging profile. For hanging the curtain on a wall, you can order wall-mounting consoles as an accessory (see Accessories). The hanging profile is a component of the curtain's standard delivery.

Illustration 1 - hanging profile (standard equipment)



Lateral version of the curtains

The lateral version of the curtains is determined according to the view towards the intake panel. The C1 curtain with water heating is manufactured as right-hand, i.e. the connection of the water heaters is on the right side. The electrical connection of the C1 curtains is also on the right side.

Illustration 2 - basic description of C1 series curtain

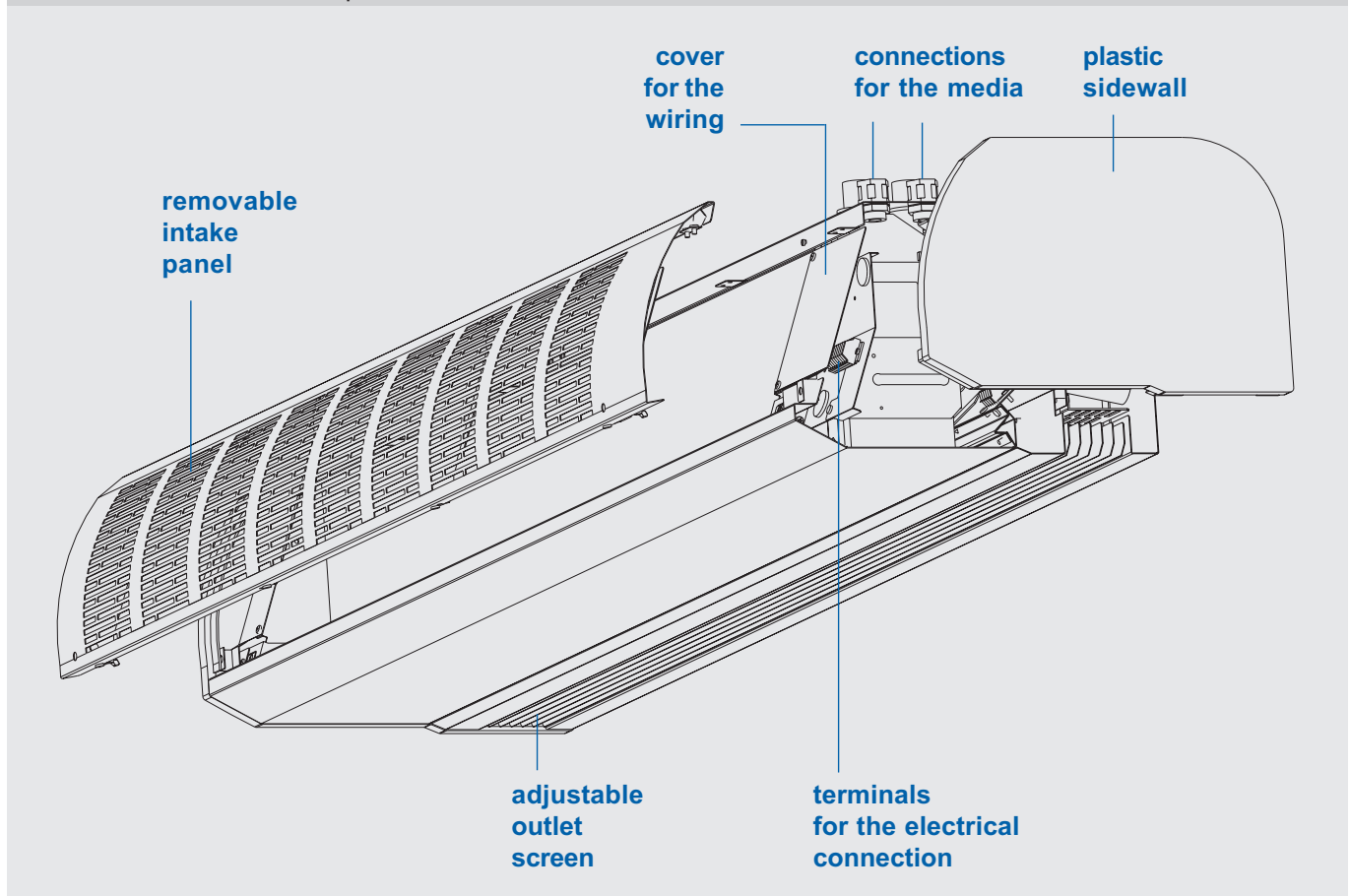

Dimensions and arrangements

Illustration 3 - dimensions of the C1 series curtains

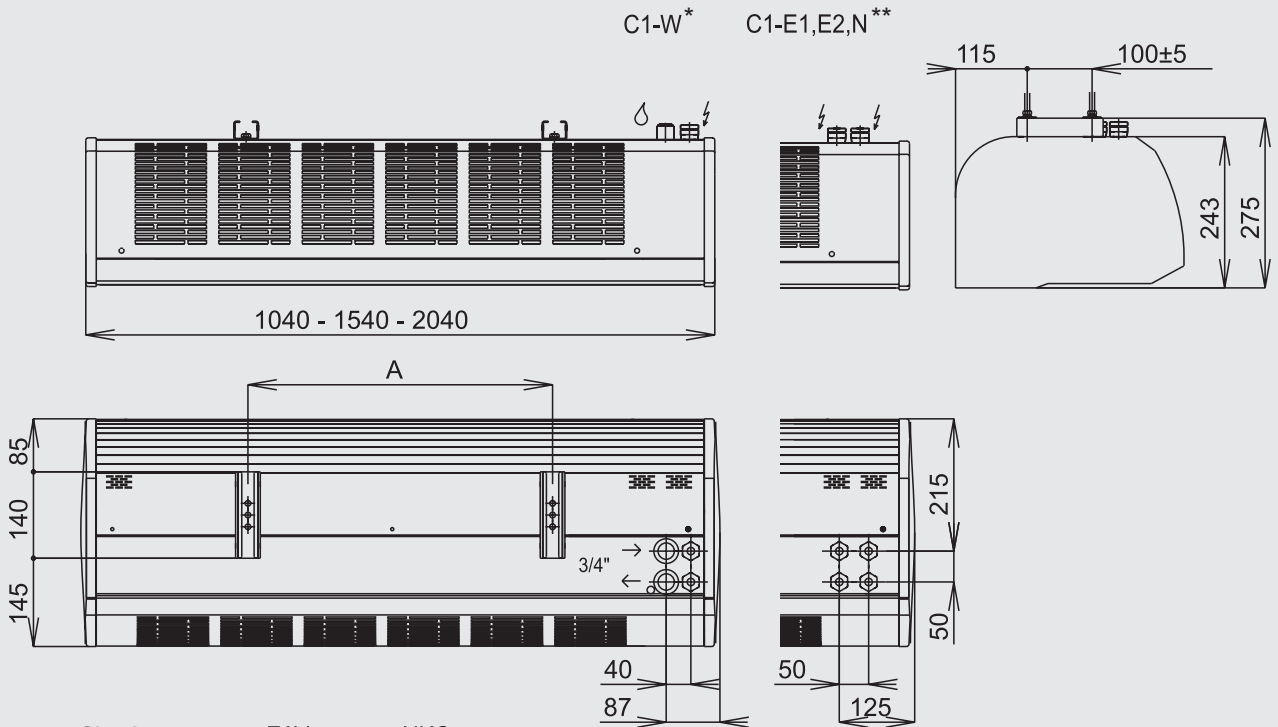

Size A	ZAV	NKC
C1-100	1x 500	1x 500
C1-150	1x1000	1x1000
C1-200	1x1500	3x 500

ZAV – Hanging on hanging profile
NKC – Hanging on wall console

* W: curtain with water heating
** E1, E2: curtain with el. heating, N: curtain without heating

Designation

The Doormaster air curtains of the C1 series are generally designated by an alphanumeric code according to illustration No. 4.

Illustration 4 - designation of C1 series curtains

C1 - E1 - 150 / TR-M

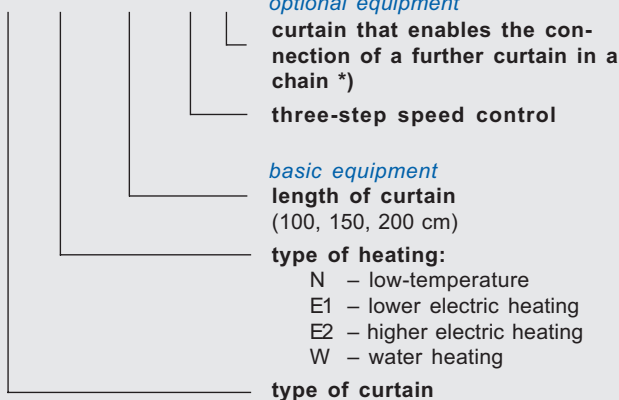

*) This designation is used only for the version with electric heating; standard curtains are chained on the other versions. For more see the chapter "Chaining of Curtains", page 16.

Heating of air

The heating of the air is the second important function of the curtain. The heating provides the mixing of the cool air entering into the room with the heated air flowing from the curtain. The curtains are delivered with water or electric heating. The use of curtains without heating is suitable only in exceptional cases where the heating of the air is not wanted (in cooled areas for example).

Electric heating

The heating of the air (versions E1 and E2) is accomplished by means of an electric heating register that is formed from stainless, low-temperature heating rods with a large heat-exchanging surface. You can select the electric heating output from two variations - the output variation is determined by the letters E1 and E2 in the curtain designation: E1 is a variation with a lower heating output; the variation E2 has a higher electric heating output. On curtains in the E1 version, only the whole output can be switched; on curtains in the E2 version, the whole or one-half electric heating output can be switched.

The protections against the over-heating of the electric heater or of the curtains are listed in the chapter "Control" on page 12.

Heating, heating outputs

Illustration 5 - curtain with electric heating

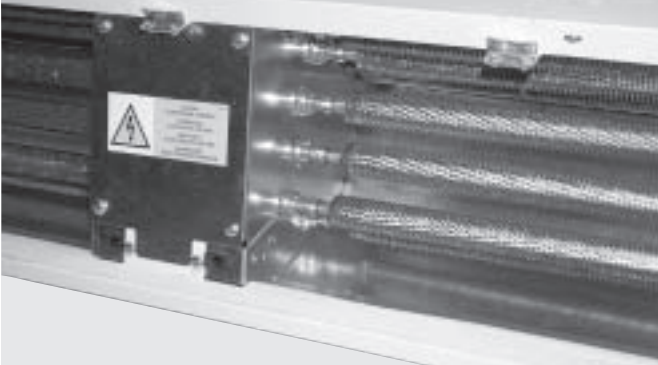
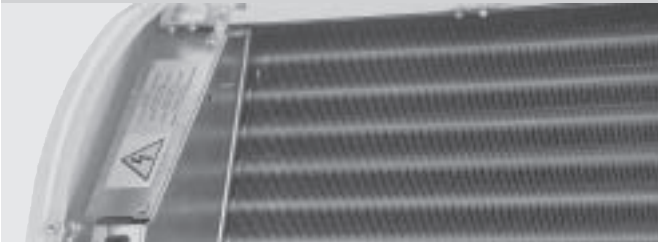

Illustration 6 - curtain with water heating



Water heating

The water heating (version W) is provided by a two-row water heater with vanes. The curtains of the C1 version are equipped with one body of a water exchanger in all lengths. Thus the connection of the water heating is only on one spot. The curtains with a water exchanger are designed for a heating medium with a maximum temperature of 90°C and for a maximum operating pressure of 1.6 MPa.

When high-temperature heating is employed (max. 130°C), it is necessary to equip the feed-in of the heating medium with a valve controlled by a thermostat (TVW-P, see page 16) and limit the output of the exchanger to the max. temperature of an outlet air of 50°C (setting of the thermo-valve head) or to use a control by means of a mixing set.

Table 1 - heating outputs with an el. exchanger

Curtain	C1-E1-100	C1-E1-150	C1-E1-200
Input	4,5 kW	6,75 kW	9,0 kW
Curtain	C1-E2-100	C1-E2-150	C1-E2-200
Input	9,0 kW	13,5 kW	18,0 kW

Table 2 - parameters of the exchangers on C1-W curtains (two-row exchanger)

type of curtain	water flow (l/s)	water flow (m3/h)	pressure loss of water (kPa)	III. output step		II. output step		I. output step		pressure loss TVW-P (kPa) *	pressure loss TVW-E (kPa) *
				heating output (kW)	delta t (°C)	heating output (kW)	delta t (°C)	heating output (kW)	delta t (°C)		
60/40°C											
C1-W-100	0,05	0,18	3,0	4,7	18/30,5	4,1	18/32	3,6	18/33	0,1	0,5
C1-W-150	0,08	0,29	3,1	7,2	18/31	6,3	18/33	5,7	18/34	0,3	1
C1-W-200	0,11	0,40	2,5	9,8	18/31	8,4	18/32,5	7,7	18/33,5	0,5	1,7
80/60°C											
C1-W-100	0,09	0,32	7,6	8,1	18/40	7,0	18/42	6,2	18/44	0,3	0,8
C1-W-150	0,14	0,50	7,6	12,4	18/41	10,7	18/43	9,7	18/45	0,8	2,2
C1-W-200	0,20	0,72	6,1	16,8	18/40,5	14,5	18/43	13,1	18/44,5	1,7	4,2
90/70°C											
C1-W-100	0,11	0,40	10,4	9,8	18/44	8,4	18/47	7,5	18/49,5	0,5	1,4
C1-W-150	0,17	0,61	10,4	15,0	18/45,5	12,9	18/48,5	11,6	18/50,5	1,2	3,2
C1-W-200	0,24	0,86	8,3	20,2	18/45	17,4	18/48	15,8	18/51	2,5	6,2
95/70°C + thermostat valve with control setting of max. 50 °C											
C1-W-100	0,09	0,32	7,3	10,1	18/45	8,7	18/48	7,7	18/50	0,3	
C1-W-150	0,14	0,50	7,3	15,4	18/46	13,4	18/49	11,7	18/50	0,8	
C1-W-200	0,20	0,72	5,9	21,0	18/46	18,0	18/49	16,1	18/50	1,7	
100/80°C + thermostat valve with control setting of max. 50 °C											
C1-W-100	0,13	0,47	13,4	11,5	18/48,5	9,4	18/50	7,8	18/50	0,7	
C1-W-150	0,20	0,72	13,3	17,5	18/50	13,8	18/50	11,6	18/50	1,7	
C1-W-200	0,28	1,01	10,7	23,7	18/50	18,6	18/50	16,1	18/50	3,4	
110/90°C + thermostat valve with control setting of max. 50 °C											
C1-W-100	0,09	0,32	6,5	12,0	18/50	9,3	18/50	7,7	18/50	0,3	
C1-W-150	0,12	0,43	5,0	17,7	18/50	13,8	18/50	11,5	18/50	0,6	
C1-W-200	0,16	0,58	4,0	24,0	18/50	18,8	18/50	15,9	18/50	1,1	
130/90°C + thermostat valve with control setting of max. 50 °C											
C1-W-100	0,04	0,14	1,9	12,0	18/50	9,3	18/50	7,8	18/50	0,1	
C1-W-150	0,06	0,22	1,5	17,5	18/50	13,8	18/50	11,5	18/50	0,2	
C1-W-200	0,08	0,29	1,3	24,3	18/50	19,0	18/50	16,1	18/50	0,3	

When operating a curtain at a lower speed step, the temperature of the return water can rise to the value given by the temperature drop (max. 5°C). In case there are problems with such an increase, we recommend using the thermostat valve (TVW-P, mounted on the intake branch) and setting the controller (head) at the value of the temperature of the outlet air listed in the column delta t (°C) in the I. output step (for example, the C1-W-100 curtain, warm-water circulation 60/40: set the controller at a value of max. 33°C). The thermostat valve reduces the flow of water, thus ensuring its greater cooling. By doing so, the maintaining of the temperature drop is guaranteed. For warm-water circulations above 90/70, it is necessary to use a thermostat valve, and by setting it at max. 50°C, there is ensured, among other things, that the temperature of the return water does not exceed the specified value given by the temperature drop.

Technical parameters
N Low-temperature

W Water heating

DoorMaster C1		C1-N-100	C1-N-150	C1-N-200	C1-W-100	C1-W-150	C1-W-200
Width of door (max.)	mm	1.000	1.500	2.000	1.000	1.500	2.000
Total width of curtain	mm	1.040	1.540	2.040	1.040	1.540	2.040
Height of the curtain body	mm	240	240	240	240	240	240
Depth of the curtain body	mm	365	365	365	365	365	365
Weight (1-speed / 3-speed)	kg	23 / 24,5	30,5 / 32	39 / 40,5	25 / 26	33,5 / 34,5	44 / 46
Airflow (max.)	m³/h	1.200	1.800	2.400	1.100	1.600	2.200
Nominal voltage		230 V / 50 Hz			230 V / 50 Hz		
Input power of fans	kW	0,13	0,22	0,26	0,13	0,22	0,26
Current through the fans	A	0,6	1	1,2	0,6	1	1,2
Heating output *	kW				8,3	13	17,5
Heating current	A						
Total input power	kW	0,13	0,22	0,26	0,13	0,22	0,26
Total current	A	0,6	1	1,2	0,6	1	1,2
III. Step							
Airflow	m³/h	1.200	1.800	2.400	1.100	1.600	2.200
Acoustic pressure *	dB(A)	52	53	55	51	52	54
Acoustic output *	dB(A)	64	65	67	63	64	66
II. step							
Airflow	m³/h	950	1.400	1.850	850	1.250	1.700
Acoustic pressure *	dB(A)	50	52	53	49	51	52
Acoustic output *	dB(A)	62	64	65	61	63	64
I. step							
Airflow	m³/h	800	1.200	1.600	700	1.050	1.450
Acoustic pressure *	dB(A)	50	52	53	48	50	51
Acoustic output *	dB(A)	62	64	65	60	62	63

* Water 80/60°C; intake power of heating rods

* Acoustic pressure at a distance of 3.0 m, directional factor 2 and absorption surface 200 m2

** Acoustic output according to ČSN ISO 3743-2

E1 Electric heating E1

E2 Electric heating E2

DoorMaster C1		C1-E1-100	C1-E1-150	C1-E1-200	C1-E2-100	C1-E2-150	C1-E2-200
Width of door (max.)	mm	1.000	1.500	2.000	1.000	1.500	2.000
Total width of curtain	mm	1.040	1.540	2.040	1.040	1.540	2.040
Height of the curtain body	mm	240	240	240	240	240	240
Depth of the curtain body	mm	365	365	365	365	365	365
Weight (1-speed / 3-speed)	kg	24 / 25	32,5 / 34	42,5 / 44	26 / 27	33,5 / 34,5	44 / 46
Airflow (max.)	m³/h	1.200	1.800	2.400	1.200	1.800	2.400
Nominal voltage		3 x 400 V / 50 Hz			3 x 400 V / 50 Hz		
Input power of fans	kW	0,13	0,22	0,26	0,13	0,22	0,26
Current through the fans	A	0,6	1	1,2	0,6	1	1,2
Heating output *	kW	4,5	6,75	9	9	13,5	18
Heating current	A	7,3	11	14,5	14,5	22	29
Total input power	kW	4,65	7	9,3	9,15	13,7	18,3
Total current	A	8	12	15,5	15	23	30
III. Step							
Airflow	m³/h	1.200	1.800	2.400	1.200	1.800	2.400
Acoustic pressure *	dB(A)	52	53	55	52	53	55
Acoustic output *	dB(A)	64	65	67	64	65	67
II. step							
Airflow	m³/h	900	1.400	1.850	900	1.400	1.850
Acoustic pressure *	dB(A)	51	52	53	50	52	53
Acoustic output *	dB(A)	62	64	65	62	64	65
I. step							
Airflow	m³/h	800	1.200	1.600	800	1.200	1.600
Acoustic pressure *	dB(A)	49	51	52	49	51	52
Acoustic output *	dB(A)	61,5	63,5	64,5	61,5	63,5	64,5

* Water 80/60°C; intake power of heating rods

* Acoustic pressure at a distance of 3.0 m, directional factor 2 and absorption surface 200 m2

** Acoustic output according to ČSN ISO 3743-2

Technical parameters

Table 3 - Max. temperature gradient ΔT [°C] of electric heating at the given temperature of the surroundings

	C1-E1-100	C1-E2-100	C1-E1-150	C1-E2-150	C1-E1-200	C1-E2-200
kW	4,5	9	6,75	13,5	9	18
III. Step						
m ³ /h	1200	1200	1800	1800	2400	2400
0 °C	10,0	20,0	10,0	20,0	10,0	20,0
10 °C	10,4	20,7	10,4	20,7	10,4	20,7
20 °C	10,7	21,4	10,7	21,4	10,7	21,4
II. Step						
m ³ /h	950	950	1400	1400	1850	1850
0 °C	12,6	25,3	12,9	25,7	13,0	26,0
10 °C	13,1	26,2	13,3	26,7	13,5	26,9
20 °C	13,5	27,0	13,7	27,5	13,9	27,7
I. Step						
m ³ /h	800	800	1200	1200	1600	1600
0 °C	15,0	30,0	15,0	30,0	15,0	30,0
10 °C	15,6	31,1	15,6	31,1	15,6	31,1
20 °C	16,0	32,1	16,0	32,1	16,0	32,1

In the case of electric heating, the outlet temperature of the air is dependent on the output step selected for the fans and the heating step selected. The heating yield [°C] can be determined roughly according to the general formula:

$\Delta T = Q[W] \cdot 0,95 \cdot 3600 / (V[m^3/h] \cdot \rho[kg/m^3] \cdot c[J/kgK])$, where ρ is the density of the air at the presupposed temperature of (+20°C: 1.188 kg/m³) and c the specific heating capacity of the air at the presupposed temperature of (+20°C: 1010 J/kg·K-1).

t	ρ	c
°C	kg/m ³	J/(kgK)
-20	1,376	1009
0	1,275	1005
10	1,23	1005
20	1,188	1010

Basic information

Usage

DoorMaster curtains of the D1 series are intended for inside installation above an entrance door. The maximum installation height recommended is 3 m. Their modern design enables them to be used in architecturally demanding structures. Typical places for their installation are administration centers, hypermarkets, restaurants, post offices, garages, warehouses etc.

Description of construction

The D2 curtains are formed by an internal chassis and covering panels of lacquered sheet metal in the color shade of RAL 9002. The exhaust chamber is furnished with anti-noise insulation. The removable intake panel with an integrated filter insert and a bottom service panel ensure easy access to the internal elements. Components from leading European companies are used in the curtains. The radial fans that suck on both sides have three-step speed control. The motor and impellers are on a common shaft. Over-all protection of the covered curtain is IP 20. The fans are equipped with motors having a temperature insulation of the windings of class F. The motors are furnished with a lead-out thermo-contact (to the cable), which ensures that the power supply to the motor or to the electric heating is disconnected when there is an overload. Short-circuit protection of the motors and control circuits is provided with the help of front-end fuses.

Manner of hanging

D2 curtains are hung on M8 hanging rods behind a hanging profile. The hanging profile is a component of the curtain's delivery.

Illustration 7 - hanging profile

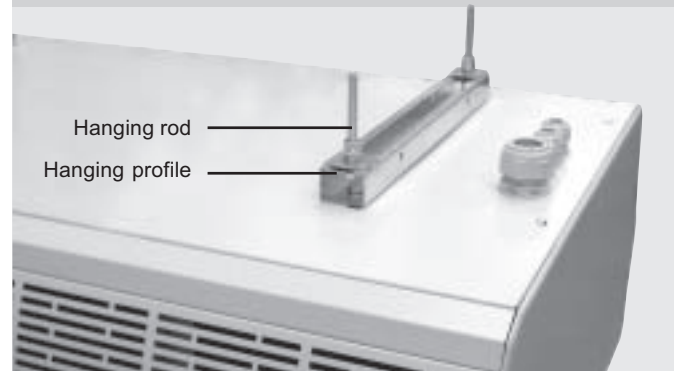

Lateral version of the curtains

The lateral version of the curtains is determined according to the view towards the intake panel. The D2 curtain with water heating is manufactured as left-hand, i.e. the connection of the water heaters is on the left side. The electrical connection of the D2 curtains is on the right side.

Illustration 8 - basic description of the D2 series curtain

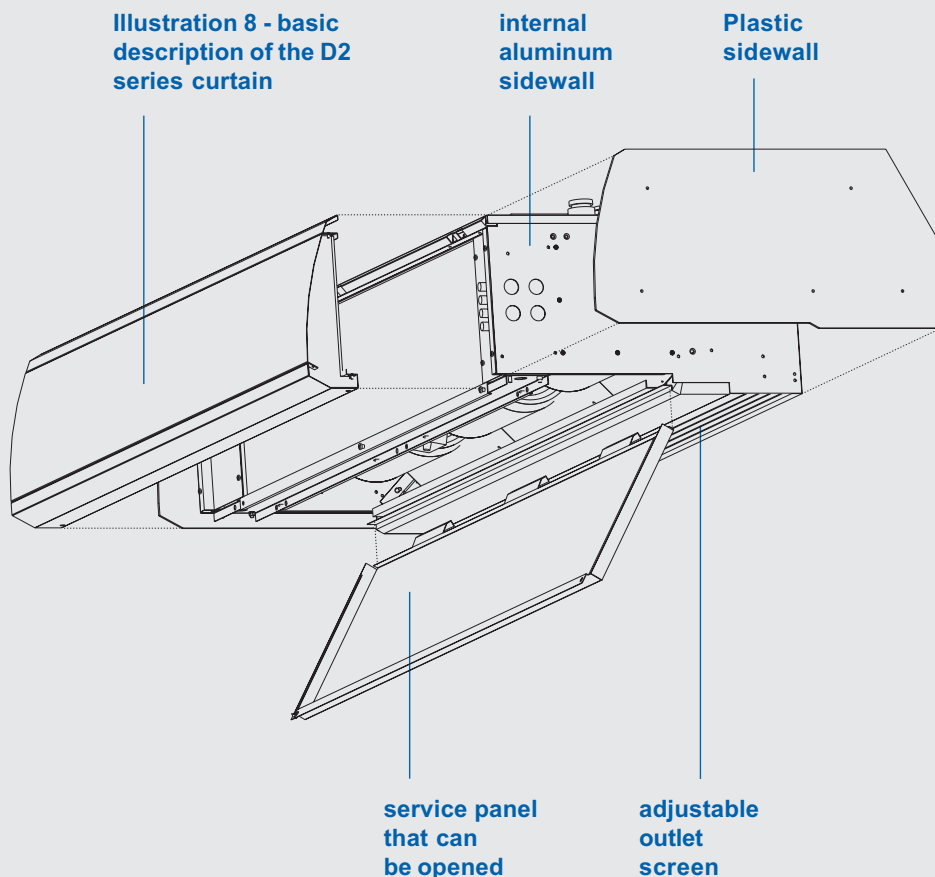

Sizes and arrangements

Illustration 9 - dimensions of the D2 series curtains

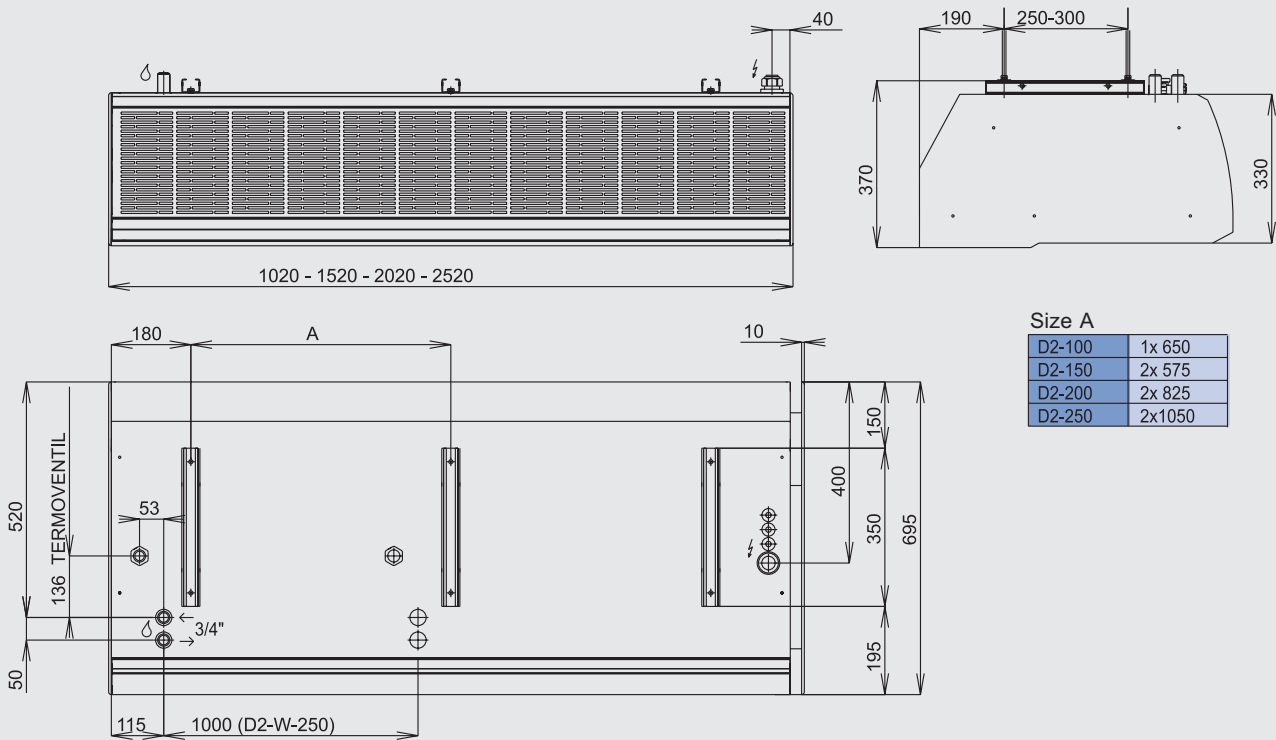

Size A	
D2-100	1x 650
D2-150	2x 575
D2-200	2x 825
D2-250	2x 1050

Type marking

The DoorMaster air curtains of the D2 series are generally marked by alphanumeric code according to the following scheme:

Illustration 10 - D2 air curtains marking

D2 - W - 100 / M

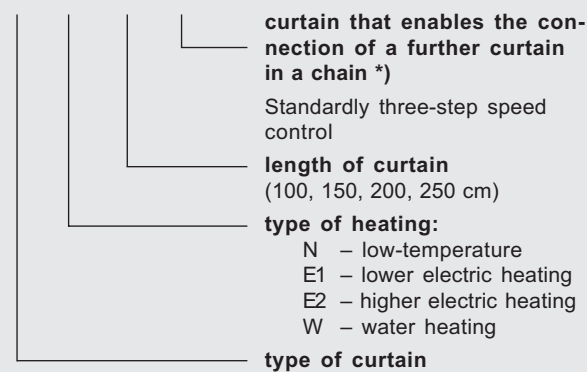

*) See the chapter "Chaining of curtains"

Heating of the air

The heating of the air is the second important function of the curtain. The curtains are delivered with water or electric heating. The use of the low-temperature curtains (without heating) is suitable in reasonable cases when the heating of the air is undesirable.

Electric heating

The heating of the air (versions E1 and E2) is accomplished by means of an electric heating register that is formed from stainless, low-temperature heating rods with a large heat-exchanging surface. You can select the electric heating output from two variations (see the Table 4). The output variation is determined by the letters E1 and E2 in the curtain designation. E1 is the variation with a lower heating output (2 steps of output); the E2 variation has a higher electric heating output (3 steps of output).

Illustration 11 - The Curtain with electric heating

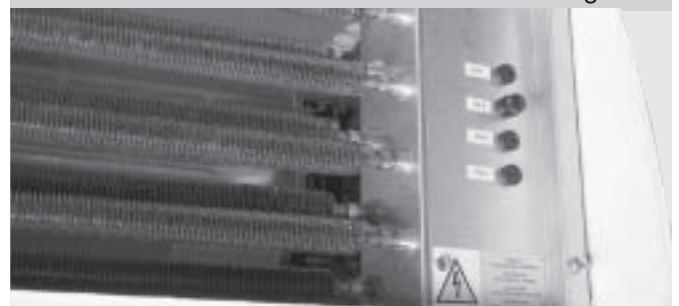

Designations, heating outputs

The maximum outlet temperature of the air from the curtain is dependent on the fan-speed set or on the setting of the control thermostat, max. 50°C.

1.6 MPa. When high-temperature heating is employed (max. 130°C), it is necessary to equip the feed-in of the heating medium with a valve controlled by a thermostat and limit the output of the exchanger to the max. temperature of an outlet air of 50°C (setting of the thermo-valve head) or to use a control by means of a mixing set.

Table 4 - heating output with an electric exchanger

Curtain	D2-E1-100	D2-E1-150	D2-E1-200
Input	9,0 kW	13,5 kW	18,0 kW
Curtain	D2-E2-100	D2-E2-150	D2-E2-200
Input	13,5 kW	20,3 kW	27,0 kW

Water heating

The water heating (W version) is provided by a three-row water heater with vanes that is formed by one exchanger body for lengths of 1 m, 1.5 m and 2 m and by two exchanger bodies (double connection) at a curtain length of 2.5 m. The curtains with a water exchanger are designed for a heating medium of up to a maximum temperature of 90°C and for a maximum operating pressure of

Illustration 12 - curtain with water heating



Table 5 - parameters of D2-W curtains exchangers (three-row exchanger)

type of curtain	water flow (l/s)	water flow (m3/h)	pressure loss of water (kPa)	III. output step		II. output step		I. output step		press. loss TVW-P (kPa) *	press. loss TVW-E (kPa) *
				heating output (kW)	delta t (°C)	heating output (kW)	delta t (°C)	heating output (kW)	delta t (°C)		
60/40°C											
D2-W-100	0,11	0,4	0,8	9,3	18/31	8,4	18/32	7,1	18/34	0,5	1,5
D2-W-150	0,18	0,65	1,3	15,2	18/32,5	13,8	18/33,5	11,4	18/35,5	1,4	3,5
D2-W-200	0,24	0,86	1,1	20,8	18/32,5	18,8	18/34	15,7	18/35,5	2,5	6,2
80/60°C											
D2-W-100	0,19	0,68	2,2	16,6	18/41,5	15,0	18/43	12,5	18/46,5	1,5	4
D2-W-150	0,31	1,12	3,4	26,6	18/43	24,0	18/45	19,8	18/48,5	4,2	11
D2-W-200	0,43	1,55	2,8	36,5	18/43,5	32,8	18/45,5	27,3	18/49	8	20
90/70°C											
D2-W-100	0,24	0,86	3,0	20,2	18/46,5	18,2	18/48,5	15,2	18/52,5	2,5	6,2
D2-W-150	0,38	1,37	4,6	32,2	18/48,5	29,0	18/51	23,9	18/55	6,2	15
D2-W-200	0,52	1,87	3,8	44,2	18/49	39,7	18/51,5	32,9	18/55	11,5	30
95/70°C + thermostat valve with control setting of max. 50 °C											
D2-W-100	0,19	0,68	2,1	20,8	18/47	18,7	18/50	14,2	18/50	1,5	
D2-W-150	0,31	1,12	3,2	33,2	18/50	28,3	18/50	20,6	18/50	4,2	
D2-W-200	0,43	1,55	2,7	45,6	18/50	38,2	18/50	28,4	18/50	8	
100/80°C + thermostat valve with control setting of max. 50 °C											
D2-W-100	0,22	0,79	2,6	22,8	18/50	19,2	18/50	14,3	18/50	2	
D2-W-150	0,26	0,94	2,3	33,9	18/50	28,5	18/50	20,6	18/50	3	
D2-W-200	0,34	1,22	1,7	46	18/50	38,5	18/50	28,5	18/50	5	
110/90°C + thermostat valve with control setting of max. 50 °C											
D2-W-100	0,14	0,50	1,1	23	18/50	19,1	18/50	14,3	18/50	0,8	
D2-W-150	0,17	0,61	1,1	33,9	18/50	28,5	18/50	20,8	18/50	1,2	
D2-W-200	0,23	0,83	0,9	45,9	18/50	38,3	18/50	28,6	18/50	2,3	
130/90°C + thermostat valve with control setting of max. 50 °C											
D2-W-100	0,08	0,29	0,4	22,8	18/50	19	18/50	14,3	18/50	0,3	
D2-W-150	0,10	0,36	0,4	33,6	18/50	28,5	18/50	20,8	18/50	0,4	
D2-W-200	0,14	0,50	0,4	46	18/50	38,6	18/50	28,4	18/50	0,8	

When operating a curtain at a lower speed step, the temperature of the return water can rise to the value given by the temperature drop (max. 5°C). In case there are problems with such an increase, we recommend using the thermostat valve (TVW-P or TVW-R, mounted on the intake branch) and setting the controller (head) at the value of the temperature of the outlet air listed in the column delta t (°C) in the I. output step (for example, the D2-W-100 curtain, warm-water circulation 60/40: set the controller at a value of max. 34°C). The thermostat valve reduces the flow of water, thus ensuring its greater cooling. By doing so, the maintaining of the temperature drop is guaranteed. For warm-water circulations above 90/70, it is necessary to use a thermostat valve, and by setting it at max. 50°C, there is ensured, among other things, that the temperature of the return water does not exceed the specified value given by the temperature drop.

Technical parameters

N Low-temperature

W Water heating

DoorMaster D2		D2-N-100	D2-N-150	D2-N-200	D2-N-250	D2-W-100	D2-W-150	D2-W-200	D2-W-250
Width of door (max.)	mm	1.000	1.500	2.000	2.500	1.000	1.500	2.000	2.500
Total width of curtain	mm	1.020	1.520	2.020	2.520	1.020	1.520	2.020	2.520
Height of the curtain body	mm	340	340	340	340	340	340	340	340
Depth of the curtain body	mm	700	700	700	700	700	700	700	700
Weight (1-speed / 3-speed)	kg	53	83	110	135	60	88	118	150
Airflow (max.)	m ³ /h	2 300	3 500	4 600	5 800	2 150	3 250	4 300	5 400
Nominal voltage		230 V / 50 Hz				230 V / 50 Hz			
Input power of fans ***	kW	0,42	0,6	0,84	1,02	0,42	0,6	0,84	1,02
Current through the fans ***	A	3,7	4,8	7,4	8,5	3,7	4,8	7,4	8,5
Heating output (80/60°C)	kW					18	29	40	50
III. Step									
Airflow	m ³ /h	2 300	3 400	4 600	5 700	2 100	3 100	4 200	5 200
Acoustic pressure *	dB(A)	61	63	64	66	60	62	63	65
Acoustic output **	dB(A)	77	78,5	80	82	76	77,5	79	81
II. step									
Airflow	m ³ /h	1 900	2 800	3 800	4 700	1 750	2 600	3 500	4 400
Acoustic pressure *	dB(A)	57	59	60	62	55	57	58	60
Acoustic output **	dB(A)	72	73,5	75	77	71	72,5	74	76
I. step									
Airflow	m ³ /h	1 350	2 000	2 700	3 400	1 300	1 900	2 600	3 200
Acoustic pressure *	dB(A)	48	50	51	53	48	50	51	53
Acoustic output **	dB(A)	64	65,5	67	69	64	65,5	67	69

* Water 80/60°C; intake power of heating rods

* Acoustic pressure at a distance of 3.0 m, directional factor 2 and absorption surface 200 m²

** Acoustic output according to ČSN ISO 3743-2

E1 Electric heating E1

E2 Electric heating E2

DoorMaster D2		D2-E1-100	D2-E1-150	D2-E1-200	D2-E1-250	D2-E2-100	D2-E2-150	D2-E2-200	D2-E2-250
Width of door (max.)	mm	1.000	1.500	2.000	2.500	1.000	1.500	2.000	2.500
Total width of curtain	mm	1.020	1.520	2.020	2.520	1.020	1.520	2.020	2.520
Height of the curtain body	mm	340	340	340	340	340	340	340	340
Depth of the curtain body	mm	700	700	700	700	700	700	700	700
Weight (1-speed / 3-speed)	kg	58	87	116	148	60	88	118	150
Airflow (max.)	m ³ /h	2 300	3 500	4 600	5 800	2 300	3 500	4 600	5 800
Nominal voltage		3 x 400 V / 50 Hz				3 x 400 V / 50 Hz			
Input power of fans ***	kW	0,42	0,6	0,84	1,02	0,42	0,6	0,84	1,02
Current through the fans ***	A	3,7	4,8	7,4	8,5	3,7	4,8	7,4	8,5
Heating output (heating rods)	kW	9	13,5	18	22,5	13,5	20,3	27	33,8
Heating current	A	14	20,5	27,5	34,5	20,5	31	41	51,5
Total current	A	18	25,3	35	43	25	36	49	60
III. Step									
Airflow	m ³ /h	2 300	3 400	4 600	5 700	2 300	3 400	4 600	5 700
Acoustic pressure *	dB(A)	61	63	64	66	61	63	64	66
Acoustic output **	dB(A)	77	78,5	80	82	77	78,5	80	82
II. step									
Airflow	m ³ /h	1 900	2 800	3 800	4 700	1 900	2 800	3 800	4 700
Acoustic pressure *	dB(A)	57	59	60	62	57	59	60	62
Acoustic output **	dB(A)	72	73,5	75	77	72	73,5	75	77
I. step									
Airflow	m ³ /h	1 350	2 000	2 700	3 400	1 350	2 000	2 700	3 400
Acoustic pressure *	dB(A)	48	50	51	53	48	50	51	53
Acoustic output **	dB(A)	64	65,5	67	69	64	65,5	67	69

* Water 80/60°C; intake power of heating rods

* Acoustic pressure at a distance of 3.0 m, directional factor 2 and absorption surface 200 m²

** Acoustic output according to ČSN ISO 3743-2

Technical parameters
Table 6 - Max. temperature gradient ΔT [°C] of electric heating at the given temperature of the surroundings

	D2-E1-100	D2-E2-100	D2-E1-150	D2-E2-150	D2-E1-200	D2-E2-200	D2-E1-250	D2-E2-250
kW	9	13,5	13,5	20,3	18	27	22,5	33,8
III. Step								
m ³ /h	2300	2300	3400	3400	4600	4600	5700	5700
0 °C	10,4	15,7	10,6	15,9	10,4	15,7	10,5	15,8
10 °C	10,8	16,2	11,0	16,5	10,8	16,2	10,9	16,4
20 °C	11,2	16,7	11,3	17,0	11,2	16,7	11,3	16,9
II. Step								
m ³ /h	1900	1900	2800	2800	3800	3800	4700	4700
0 °C	12,6	19,0	12,9	19,4	12,6	19,0	12,8	19,2
10 °C	13,1	19,7	13,3	20,1	13,1	19,7	13,2	19,9
20 °C	13,5	20,3	13,7	20,7	13,5	20,3	13,6	20,5
I. Step								
m ³ /h	1350	1350	2000	2000	2700	2700	3400	3400
0 °C	17,8	26,7	18,0	27,1	17,8	26,7	17,7	26,5
10 °C	18,4	27,7	18,7	28,1	18,4	27,7	18,3	27,5
20 °C	19,0	28,5	19,2	28,9	19,0	28,5	18,9	28,3

Control, protection, blocking

Connection and protection

- As standard equipment, the curtains are furnished with terminals for connecting an external device (switches / change-over switches) - the curtain does not carry any control elements.
- Preliminary protection against a short-circuit must be provided by a trip release apart from the curtain.
- To safely disconnect the device from the electricity network, there must be a front-end, main - service, locking shut-off switch.
- The lead-in and control cables are led into the curtain from above; the curtains are furnished with sealing bushings on the upper side.
- The motors of the fans on all curtains are furnished with protective thermo-contacts.
- The curtains have all the necessary protection elements for ensuring the safety of their operation.

Control of fan speed

A reduction in speed limits the curtain's efficiency; nevertheless in some applications, it is expedient to use such a measure (particularly for the function of additional heating; when the door is shut, for reducing operating noise).

In the basic version, D2 curtains are equipped with motors whose output can be controlled in 3 steps by adding a suitable front-end controller.

In the basic version, C1 curtains are delivered without a control of fan speed - upon request, a 3-step speed controller can be integrated into the curtain. The controller weighs approximately 1.5 kg.

Any suitably dimensioned, single-pole switch can be used for switching one-speed curtains. The manufacturer of the curtain does not deliver such switches. Controllers for curtains with a control of fan output can be ordered as a separate accessory together with the curtain, see page 14.

Note: Wiring diagrams for the curtains and a description of the connecting terminals are contained in the installation instructions, which are enclosed in every curtain.

Control of C1 and D2 electric heating

C1-E1 curtains are equipped with an electric heater with one section, which makes only one-step operation possible, i.e. during heating control, full heater output is switched.

The other curtains with electric heating, i.e. C1-E2 and all D2 (E1 and E2) curtains, are equipped with an electric heater that is divided into two separate sections, which make multi-step operation possible, see table 5 on page 11.

The two-section heating register can be controlled by a double switch (I-II), or it can use the RAB 90E three-step controller (see the chapter "Accessories").

According to the temperature of the air with the help of a room thermostat, an automatic control can be substituted for the manual control of heating output, see the chapter "Accessories".

The switching of the heating register occurs instantly, which also holds true for multi-step switching, (always full output). In specific cases, it is possible to use a thermostat combined with an integrated three-step control of fan speed.

Note: The controlling (room) thermostat must be located in an area that is influenced by the curtain's heating (close to a door, on the wall "under the curtain"). For a table summarizing the output classification of the curtains with electric heating and for the possible use of controllers, see page 15, table No. 5. Wiring diagrams for the curtains and a description of the connecting terminals are contained in the installation instructions, which are enclosed in every curtain.

Protection of the electric heater

The basic internal (operating) control of the outlet air temperature is provided by means of a built-in (control) thermostat.

The maximum permissible temperature setting is 45°C, which is also the one set by the manufacturer. Should it be necessary, a correction of the setting downward can be made.

Should the temperature that has been set be exceeded during the operation of the curtain, the thermostat disconnects the heating register, and the fans continue to run at the speed set by the controller; the register begins to heat again after things have cooled down.

Note: In some cases - according to the step set for fan speed (full or medium speed), or to the heating step set, and according to the surrounding conditions (quite cool) - the temperature set does not have to be reached at all, and the register can operate without interruption.

With regard to the thermal inertia of the heating register, the switching of the curtain's running by a door contact is unsuitable for curtains with electric heating - the warming up of the heating register usually takes longer than the opening and closing of the door.

Illustration 13 - TH167 control thermostat

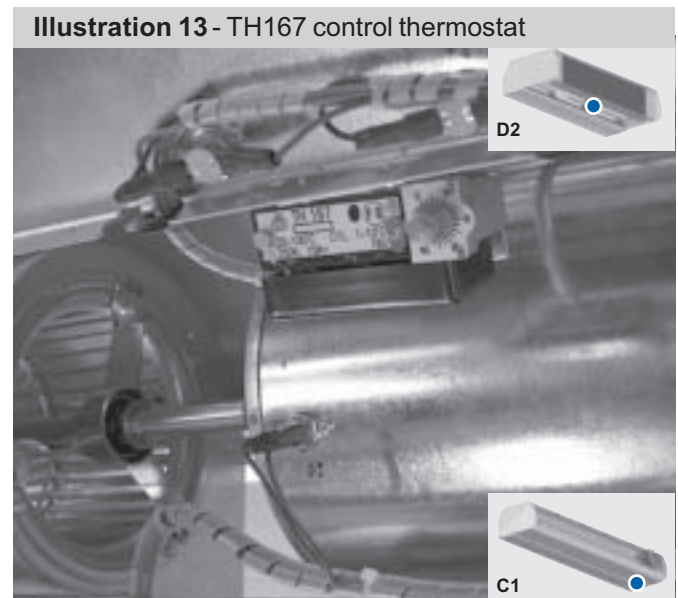

Control, protection, blocking

Blocking of the electric heater's running

The electric heater of a door curtain operates only when the fans are running (switching of the fan's contactor), and that at any speed step. Should there be no switching of the fans' running, there is no switching of the electric heater either.

Cooling down of the electric heater

When the curtain is switched off (switching off on the controller) at the moment the temperature is higher than that set on the thermostat, there is a switching to the highest output step in order to immediately cool the device down. The motors will be stopped automatically as the temperature drops.

Protection against overheating (operating and control thermostat)

Curtains with electric heating have two protective loops with thermostats that cannot be set:

- the SM2060 / 60°C protective operating thermostat.

The same system as the operating control, the protective operating thermostats (60°C) are located on the casing of the electric heater and on the spot of the fan (SM2060). They are connected in series with the windings of the electric register's contactors.

- The SM2080 / 80°C protective emergency thermostat:

The emergency thermostat (SM2080) ensures the signal for the safety disconnection of the whole curtain (i.e. the switching off of the main fuse for the inlet) in the event that the temperature exceeds the maximum tolerable limit on the body of the motor or on the heater's casing. The curtain must have a preliminary protection at the inlet that has an under-voltage ejector coil, which must be connected to the terminals of the emergency thermostat's (TK-TK) circuit - according to the enclosed connection diagram.

Important:

The curtain must have a preliminary protection at the inlet that has an under-voltage ejector coil, which must be connected to the terminals of the emergency thermostat's (TK-TK) circuit - according to the enclosed connection diagram.

Control of the water heating

As standard equipment, the curtain with water heating does not have any means for controlling the temperature of the outlet air or for heating it.

To avoid overheating the motors and the wiring, an exchanger can be connected to the warm-water circulation having a maximum temperature of 90°C. When high-temperature heating is used (max. 130°C), it is necessary to throttle the feed-in of the heating medium by a valve controlled by a thermostat, (for description see the chapter "Accessories"). Otherwise (when the temperature is exceeded), the curtain may be switched off with the help of the motor's protection thermostats.

The outlet air temperature of water heaters can be controlled using a capillary thermostatic valve TVW-P (direct). The valve is installed in the inlet heating water branch in front of the heat exchanger and outside the air-curtain (only the capillary probe is inserted into the air-curtain).

D2-type air-curtains enable the valve to be completely installed into the device TVW-R (corner).

An electric thermostatic valve TVW-E (control ON-OFF, transposition time 3 minutes) can be used to enable the heating water inlet to the heat exchanger to be opened/closed depending on the room temperature. The valve can be installed only outside the air-curtain on the inlet branch - the valve's actuator must not be situated downwards.

Due to the valve's longer response time, this combination is not recommended if the air-curtain operation is switched by a door-contact. Max. temperature of the inlet water is up to 90°C.

Protection of the water heater

With regard to the usage application of the curtains (installation in normal areas), the matter of a specific anti-freezing protection for the water heater has not found a standard solution; the inside temperature should not drop below +5°C.

To ensure greater safety for the exchanger in winter conditions, it is necessary to safeguard the heating water (or non-freezing liquid) and the running of the pump.

When these conditions cannot be met, we recommend dismantling the curtain and moving it to heated areas. The version with an emptying valve is at your disposition upon request.

Illustration 14- thermostat valve TVW-R, D2 curtain



Accessories

Enclosed in every air curtain are:

- Operating and installation instructions
- Selected accessory elements (*according to order*)

Controllers

The means and possibilities for controlling the curtains are defined in the chapter "Control" on page 12.

The basic control of the curtain's operation without control of fan output and heating can be accomplished by using customary wall shut-off switches (ON / OFF). The shut-off switch is not a delivery component.

For controlling the curtain's operation with control of fan output or with exterior control for heating, the widespread Siemens controllers listed below can be used.

The selection of a controller depends on the type of curtain and on the requirement for control. Table No. 5 illustrates the functions and usage possibilities of the individual controllers.

Room thermostats can also be used for C1-W or D2-W curtains, but only in combination with the TVW-E thermo-electric closing valve (separate accessory).

Note: Control by means of the TVW-P thermostat valve is not possible. It is also not possible to combine the TVW-R with the control of heating using a room thermostat.

The recommended types of conductors for connecting the controllers are listed in table No. 6. Shielding is not necessary.

Illustration 15 - SIEMENS curtain controllers

Manual



RAB 90
3-step control
of fan output



RAB 90E
up to 3-step manual output
control of electric heater

Thermostat



RAA10
speed controller concealed inside the
controller (the controller is located in the
space under the curtain)



RAA20
speed controller in the front cover of the
controller (the controller is located in the
space under the curtain)



RAA30
speed controller in the front cover of the
controller + possibility of switching off the
heating (the controller is located in the
space under the curtain)

TR speed controller (C1 only)

Description: The curtains of the C1 series can be equipped with a voltage speed controller with three-step control of fan output.

Usage: To control air output in three steps on C curtains only.

Installation: by the manufacturer inside the curtain.

Ordering code: TR for the curtain type.

Example: C1-W-100/TR

Thermostat valve

Description: The DN20 thermostat valve (internal threading) with a flat insert and thermostat head with a liquid feeler and a capillary in the version:

a) direct - for installing on the inlet branch of the heating water outside the curtain on C1 and D2: Designation TVW-P

b) angle - for internal installation inside the curtain - on D2 curtains only (your own installation!): Designation TVW-R

Usage: for joint control (by throttling) of the outlet air temperature on curtains with water heating. It does not require an electrical connection and operating personnel. It is intended especially for setting/limiting the maximum outlet air temperature from a curtain with a water heater (analogous to the built-in operating thermostat in a curtain with electric heating).

Installation: the valve is installed on the inlet of the water heater (3/4"). The valve's sensing bulb and capillary must switch the outlet air temperature inside the curtain behind the heater.

Ordering code:

TVW-P - direct thermostat valve

TVW-R - angle thermostat valve (D2 only)

Note: D2-W-250 curtains have two water exchangers, and so two valves have to be ordered.

It is not recommended to use only one thermostatic valve due to its high pressure loss.

Illustration 16 - location of the thermo-valve's feeler (C1)



Illustration 17 - location of the thermo-valve's feeler (D2)



Accessories

Table 7 - control possibilities according to the type of curtain

Control possibilities	Speed control		Heating control				Possibility for connection of door contact	
	Number of speed steps	Three-step speed controller (0-1-2-3)	Number of heating steps	Three-step speed controller (0-1-2-3)	Room thermostat (on/off) with setting of temperature by user			
					RAB 90	RAB 90E		RAA 10
C1 - N	1		-					yes
C1 - W	1		1		when using TVW-E			yes
C1 - E1	1		1		yes			
C1 - E2	1		2	yes	yes			
C1 - N / TR	3	yes	-					yes
C1 - W / TR	3	yes	1		when using TVW-E			yes
C1 - E1 / TR	3	yes	1		yes			
C1 - E2 / TR	3	yes	2	yes	yes			
D2 - N	3	yes	-					yes
D2 - W	3	yes	1		when using TVW-E			yes
D2 - E1	3	yes	2	yes	yes			
D2 - E2	3	yes	3	yes	yes			

¹⁾ The operation of curtains via a door contact (DK) is not suitable on curtains with el. heating (E1 and E2) and on curtains with a water exchanger with a front-end, closing, thermo-electric valve, as the warming up of the heating takes longer than passage through the door.

Table 8 - types of connecting cables recommended for the controllers

Controller	Shut-off switch [ON-OFF]	Thermostat RAA 10, 20, 30	Controllers RAB 90 a RAB 90 E
Number of conductors	2	2	4
Types of conductors	H05VV-F 2Ax0,75	H05VV-F 2Ax0,75	H05VV-F 4Dx0,75
	JYTY 2Ax1	JYTY 2Ax1	JYTY 4Dx1
	JQTQ 2Ax0,8	JQTQ 2Ax0,8	JQTQ 4Dx0,8

Thermo-electric valve

Description: DN20 direct valve (inside thread, disc throttling element with return spring) and thermo- electric head (AC 230V, 50 Hz). State without voltage – valve closed. Transposition time 3 minutes.

Usage: For remote ON/OFF control of the outlet air temperature on curtains with water heating. Favorable in conjunction with the RAA 10-30 room thermostats.

Ordering code: TVW-E

Installation: The valve is installed on the inlet branch of the water heater (3/4") outside the curtain.

For D2-W-250 curtains, two valves must be ordered.

Illustration 18 - thermostat valve, servo actuator



Wall hanging console (C1 only)

Description: Special console made of zinc-coated sheet metal

Usage: For hanging a C1 curtain on the wall

Installation: The construction makes two fastening variations possible.

Ordering code:

DM NKC 100 ...for curtain C1-xx-100

DM NKC 150 ...for curtain C1-xx-150

DM NKC 200 ...for curtain C1-xx-200

The number of consoles in a set is given by the curtain's length.

Illustration 19 - mounting console and fastening



Accessories

Connecting pipe

Description: flexible stainless pipe G 3/4" (DN 20), of length 250 mm, max. operating pressure 1 MPa, illus. 20

Usage: Connection of curtains with water heating and hot-water outlet

Installation: The pipe is installed directly on the water heater's collector.

Ordering code: Pipe G 3/4"-250

Note: For curtains of 2.5 m length, 4 pipes must be ordered; for the other curtains, 2 pipes.

Illustration 20



connecting pipe
G 3/4"-250

Connecting set C

Description: Distancing element + screw connection, illus. 21

Usage: Connection of two neighboring curtains

Installation: The set is installed on the upper part of the neighboring curtains.

Ordering code: DM SS C1

Illustration 21



spacing element
of connecting set

Connecting set D

Description: Screw connection

Usage: Connection of two neighboring curtains in a chain, see the chapter "Chaining of Curtains"

Installation: Connection of the sidewalls of neighboring curtains by means of the designated openings

Ordering code: DM SS D2

Filtration textile

Description: Filtration textile of the G1 filtration class; the textile can be regenerated (by vacuum cleaning and rinsing in clean water); it can also be ordered as an accessory.

Usage: Protection of the curtain's interior against coarse external particles

Installation: In the intake panel of the D curtain

Ordering code: DM FND 100 for curtain D2-xx-100
DM FND 150 for curtain D2-xx-150
DM FND 200 for curtain D2-xx-200
DM FND 250 for curtain D2-xx-250

Note: As standard, C1 air-curtains are not equipped with filtering textile

Illustration 22 – filtration textile and inlet panel

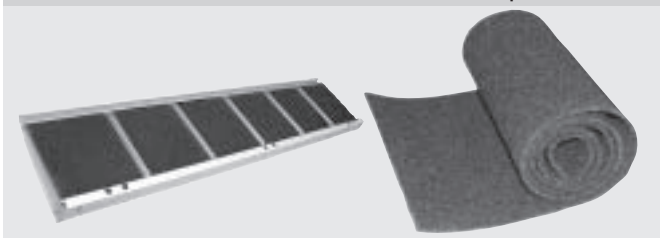

Chaining

Introduction

For door openings that are wider than can be covered by one curtain, it is necessary to use several curtains (of the same series type) installed next to each other so that the total length corresponds to the width of the opening. For a door that is 2.5 m wide, for example, it is necessary to use one curtain of 1.5 m length and one curtain with a length of at least 1.0 m.

In order for the installation of the curtains to be carried out mechanically and optically in the best possible way, connecting sets must be used (DM SS - accessory). After the electrical connections have been completed, the whole group of chained curtains is controlled according to the instructions listed below by means of a common control element (controller, thermostat) that is connected to the first curtain in the group of chained curtains; on C1 curtains, to the additional external switching block for the running of the fans. The control operates, however, on the same principles as if there was only one curtain.

Illustration 23 - mechanical connection of C1 curtains



Mechanical connection of C1 curtains

The mechanical connection of C1 curtains is possible only with the help of a connecting set. The connection is possible only from above and ensures a fixed distance between the curtains. For every connection of two curtains, one connecting set is necessary (separate accessory DM SS C1). The curtains are chained with the sidewalls.

Electrical connection

a) Fan control

For fans without speed control, the maximum number of curtains is given by the dimensioning of the switch used for the running of the curtains; the curtains are connected parallel (for the ABB TANGO No. 1 switch, for example, a maximum of 2 curtains simultaneously), or it is necessary to use a connection across an external contactor.

Chained curtains with a built-in, three-step control (C1 .../TR) can be controlled only across an additional, external, switching and separating element - relay, contactor - for each output step, one pole for each curtain (the same output steps of all curtains are lined up parallel). The individual relays or contactors (or groups) can then be switched by a common three-step controller.

Functions and combinations

b) Control of electric heating

To provide joint control (switching) of the electric heating of several curtains with electric heating, a type variation of the curtains is delivered which makes a simple joint control of heating possible. Thus the two curtain variations are differentiated by version, designation and code:

- The basic curtain (standard version for a separate installation) is used only as the last one for an installation in the context of a chained group.

- The curtain with the possibility of connecting the control of the following curtain in a chain (the first to penultimate one in a group of chained curtains) - it has the letter "M" (from the word "Master") on the end of the type designation. This version makes it possible to directly connect the control of the electric heating of the following curtain to the prepared terminals (XS) and thus to realize the chaining of the switching for the electric heating. (Note: This does not influence the joint switching of the fans, and it is necessary to provide for it externally according to the previous text.)

Note: The extended version M does not solve the switching of the fans, and it is necessary to provide for it externally according to the previous text.

c) Curtains with water heating and thermo-electric control with a room thermostat

The standard curtain version and control accessories are used for the chained control of water heating.

The thermostat can control as many valve actuators as its electric-output dimensioning allows, or it is necessary to use an output switching element (relay). The actuators are switched parallel. Apart from a separate installation to each exchanger (curtain), it is possible to design a valve and an actuator for the common feed-in of water to several curtains (the valve must have the appropriate dimensioning for flow, and an actuator corresponding to the valve must be used).

Mechanical connection of D2 curtains

The curtains can be connected to each other in such a way that they form an optically unobtrusive whole. The connection is done with the help of a connecting set (separate accessory DM SSD2).

Electrical connection

a) Fans and electric heating

The electric chaining of the curtains is not limited, and no further specific external accessory is necessary for it. A suitable combination of the type variations of the curtains provides the possibility of a simple chaining. The two curtain variations are differentiated by version, designation and code:

- The basic curtain (standard version for a separate installation) is used only as the last one for an installation in the context of a chained group.

- The curtain with the possibility of connecting the control of the following curtain in a chain (the first to penultimate one in a group) - it has the letter "M" on the end of the type designation. This version makes it possible to directly connect the control of the electric heating of the following curtain to the prepared terminals

Illustration 24 - mechanical connection of D2 curtains



(XS) and thus to realize the chaining of the switching for the electric heating and for fan speed.

The construction of the curtains makes a direct internal electrical connection possible by means of the prepared bushings in the supporting aluminum sidewalls.

b) Curtains with water heating and thermo-electric control and with a room thermostat

The standard curtain version and control accessories are used for the chained control of water heating. The thermostat can control as many valve actuators as its electric output dimensioning allows, or it is necessary to use an output switching element (relay). The actuators are switched parallel. Apart from a separate installation to each exchanger (curtain), it is possible to design a valve and an actuator for the common feed-in of water to several curtains (the valve must have the appropriate dimensioning for flow, and an actuator corresponding to the valve must be used).

Installation instructions

You will find all the information necessary for the correct installation, mounting, connection and putting into operation, including safety instructions, and for operation, maintenance and servicing of the equipment in the installation instructions, which are included in every curtain.



REMAK a.s.
Zuberská 2601
756 61 Rožnov pod Radhoštěm
Česká republika
tel.: +420 571 877 778
fax: +420 571 877 777
www.remak.eu