



caring for the environment

# HEATERS product line

Gas fired unit heaters  
to heat medium large areas  
Natural gas/LPG fired



Cyclus Print paper from Dalum is produced entirely with post-consumer recycled fibres

Robur turns the LOVE FOR BEAUTY AND WELL-MADE THINGS into innovative heating and cooling systems that are especially designed and developed to answer the specific Man needs.

## Robur Vision

Robur is dedicated to dynamic progression in research, development and promotion of safe, environmentally-friendly, energy-efficient products, through the commitment and caring of its employees and partners.

## Robur Mission

## A significant step towards Efficiency, Savings and Environmental Awareness

Robur, founded in 1956, researches, develops and produces natural gas heating and air conditioning systems with high efficiency and low environmental impact.

An exclusive feature of Robur products is their use of renewable energy sources, meaning that less pollutants are released into the atmosphere and that notable energy savings are guaranteed.

## Certified quality and latest recognition

- 1995** - ISO 9001 certification
- 2000** - 1<sup>st</sup> Prize in the Italian Regional Quality Award
- 2001** - Robur is the first ISO 9001: 2000 (Vision 2000) certified company in Europe in HVAC sector
  - 1<sup>st</sup> Prize Italian National Quality Award
- 2003** - Special Prize Winner of the European Quality Awards
  - Robur gas absorption heat pumps were included in the recommended designs group of the Environmentally Friendly Innovation Award
  - Robur, with its reversible gas absorption heat pump, claimed the Technological Innovation Award
- 2004** - Benito Guerra, chairman of Robur, received a nomination as finalist in the "Quality of life" category of the National Businessman of the Year Award, promoted by Ernst & Young
- 2005** - ISO 14001:2004 certification
  - The K range of gas-fired heaters and the GAHP-W range of gas absorption heat pumps won the honourable mention of the HVAC&R Innovation Prize sponsored by Costruire Impianti
- 2006** - Honourable mention at AHR Expo Innovation Award sponsored by ASHRAE (American Society of Heating, Refrigerating and Air-Conditioning Engineers, USA)
- 2007** - Mentioned as best product category for gas-fired heat pumps as part of the Impresa Ambiente Prize
  - Special mention in Enterprise Prize for Innovation promoted by Confindustria



The winning features of the Rour heating system	page	6
Inside the technology of Robur heaters	page	8
K Series gas fired unit heaters with variable air flow rate and modulated heat input	page	10
K CM Series gas unit heaters with centrifugal fan and mixing chamber	page	16
K - K CM Series Accessories	page	19
F Series gas unit heaters with premixing on/off burners	page	20
F C Series gas unit heaters with centrifugal fan and mixing chamber	page	24
F - F C Series Accessories	page	26
Evoluzione Series gas unit heaters with modulating burner and fan	page	28
Evoluzione Series Accessories	page	32
M - M 2v Series gas unit heaters with atmospheric burner	page	34
M C Series gas unit heaters with centrifugal fan and mixing chamber	page	38
M xt Series gas unit heaters for outdoor installation	page	40
M - M 2v - M C - M xt Series Accessories	page	42

Due to continuous product innovation and development, Robur reserves the right to change product specifications without prior notice.



More than 180,000 Robur gas fired heaters have been installed in Europe. They are ideal for industrial and commercial premises and workshops, gyms and fitness centres, warehouses and storage facilities, laboratories, commercial and trading areas, tennis courts, bowling alleys and greenhouses.

## The winning features of the Robur heating system

### Total safety in operation and reliability

The operating diagram on the right highlights the intrinsic safety of Robur heaters. When installed in the balanced flue mode optimum safety is achieved by only taking fresh combustion air into the appliance, thus ensuring no reduction in oxygen levels in the area being heated.

Also all products of combustion are exhausted outdoors. A high level of reliability is achieved by two exclusive technical features:

- a completely weld free combustion chamber resulting in extremely low levels of mechanical stress;
- the use of only the highest quality components.

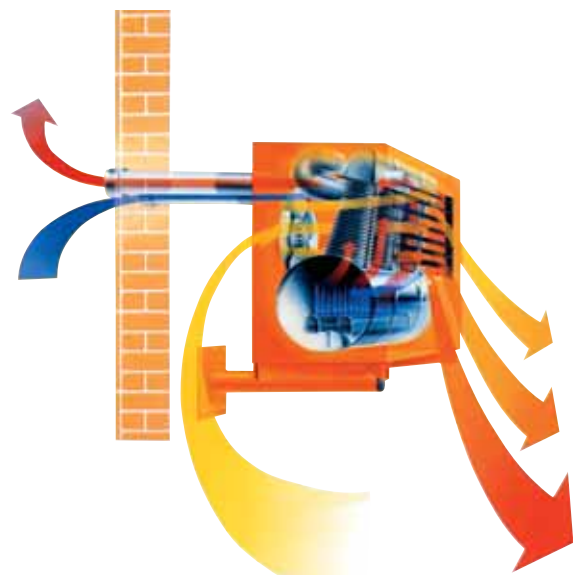

**High efficiency without thermal inertia**

The Robur air to air heat exchanger ensures extremely high efficiency. The Robur system avoids the need to install costly water pipeline which is not only expensive to install, but is also a source of heat loss. With a modular Robur installation, within 30 minutes even the largest spaces are

warmed. Tests, carried out at the Robur research and development center and at installations all over Europe, have demonstrated that given equal energy consumption Robur heaters give higher efficiency and environmental comfort than alternative systems. The figure below shows the results obtained by comparing the Robur system with two other

types of heating systems. The first system, with a traditional floor standing warm air heater, requires one and a half hours to achieve the same ambient conditions. The second system, based on radiant tubes, even after four hours is not able to reach the same level of comfort.

**No central heating plant, and lower installation costs**

Robur heaters are installed directly in the room to be heated and do not require a central heating plant or any other additional building costs. Also given the suspended nature of the installation, precious floor area is kept free.

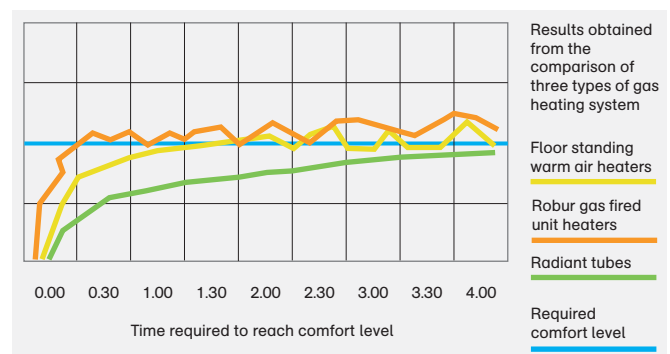

**Modularity and autonomy: heat only when and where needed**

As stand alone gas fired heaters they are suitable for modular installation. Each Robur heater is a separate, independent heating unit with the dual function of generating and diffusing heat. The heaters adapt to the variable heat requirements of different buildings, thus allowing

the number of appliances to install to be chosen, according to different requirements. Each appliance can operate independently from the others that are installed, autonomously regulating the temperature of each single zone for the length of time desired and therefore adjusting fuel consumption to actual requirements. Robur heaters are particularly suited to locations where the

modifications or expansion of the existing plant are foreseen. Finally, the Robur system guarantees constant heat even in the event of failure of one appliance, thanks to the autonomy and independence of those remaining in operation.

**Ease of installation**

Installation time and cost are kept very low. Each unit is supplied with

installation template which greatly simplifies the units installation. The three simple steps: a hole in the wall for the inlet air supply and outlet of exhausted gas, connection to the gas supply and to the electricity supply. The installation of Robur heaters is completed by a range of accessories which facilitate their fitting and operation.





The winning features of Robur's gas fired unit heaters are the result of advanced design and experience gained in over 30 years of production.

## Inside the technology of Robur heaters

### **The Robur Ground Effect: energy savings guaranteed**

The Heat Exchanger is designed with double vertical and horizontal finning, increasing internal and external heat exchanger surface. Made out of a special aluminium die-cast alloy (its high thermal conductivity is 10 times higher than steel) it allows a more homogeneous temperature on exchanger surfaces with optimal distribution. The large heat exchanger surface and the absence of high temperature areas avoid the carbonization of atmospheric dust, ensuring a perfect environmental comfort. Robur heaters allow users to reduce consumption and heat stratification problems.

Its secret is the heat exchanger - the real heart of Robur unit heaters - which splits the air flow into different layers having different temperatures: lower temperature in the higher levels and vice versa higher temperature in the lower levels. This result in the hotter lower air being kept down by the cooler higher air. Thus the different temperatures within the air-throw ensure a complete air mixing, thus reducing the temperature gradient between floor and ceiling. This exclusive Robur Ground Effect allows users to reduce consumption and heat stratification, with energy saving up to 22%.



"ROBUR GROUND EFFECT"  
thermography.

**Uniform temperatures, comfort and saving: the facts speak for themselves.**

**Stratification which causes warm air to circulate upwards into the roof space of high buildings can cause the working area to remain cool**

Tests conducted at Robur's Research and Development Centre upon various gas-based heating systems (see graph below) have shown that for systems with floor standing warm air heaters and with radiant tubes the difference in air temperature, at 1 metre and 6 metres from the ground, is approximately 9 °C, whereas with Robur heaters the temperature difference is only 1.5 °C. In addition, the ambient comfort produced by the exclusive heat exchanger guarantees a homogeneous temperature in a short time and ensures that the air is already perfectly mixed at just 4 metres from the appliance, maintaining these properties unchanged even at a great distance (40 metres and upwards) from the heater.

**Reliability and ease of maintenance with the atmospheric burner**

The Robur atmospheric burner is manufactured from high grade stainless steel and is assembled with two seamed joints to allow for expansion and to prevent surface cracking. Also the flame pattern is designed to reduce the surface temperature of the burner thus optimising heat distribution and to guarantee constant performances overtime.

Among the advantages offered by this burner:

- total reliability and durability over time;
- resistance to sudden temperature changes;
- designed for easy maintenance.

**Clean combustion and high performances with the pre-mixing burner**

The K, Evoluzione and F Series are equipped with a special multi-gas burner designed with a modulating system for proportional control of gas flow in relation to the available air at a pre-set ratio.

Among the advantages offered by this innovative burner are:

- designed for easy maintenance;
- high operational reliability;
- long service life.

In addition, this burner provides a notable reduction of NOx emissions, thereby ensuring clean combustion and greater heat efficiency and performance.

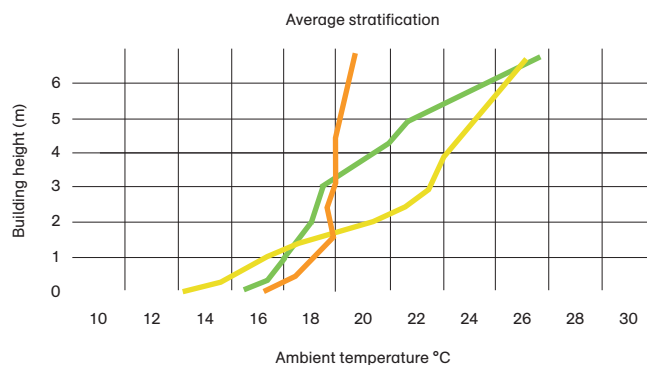
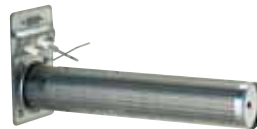

Results obtained from the comparison of three types of heating system

- Floor standing warm air heaters
- Robur gas fired unit heaters
- Radiant tubes



Continuous modulation for maximal comfort.  
K Series heaters with variable air flow rate and modulated heat input,  
with output range from 17.7 to 92 kW.

## K Series gas fired unit heaters

### The winning characteristics

- Modulation of heat output and ventilation according to ambient requirements.
- High efficiency for greater energy savings: from 92% up to over 96% at maximum heat output.
- Air intake and exhaust outlet diameter of just 80 mm, a feature that allows savings to be made also during installation.
- Digital chronothermostat supplied as standard, offers a series of important regulation and control functions, resulting

in a more precise and economical use of the heating system.

- Reduced size and weight, for faster and safer installation.
- K Series heaters have a lower size/heat output ratio than other warm air heaters currently available on the market.

### Ideal applications

Modulation of heat output and air ventilation means that the K heaters can be used efficiently in all industrial and commercial premises as:

- workshops and factories, including large ones;
- commercial buildings and showrooms;
- rooms that require heating and ventilation;
- laboratories and sports halls.



## Comfort, energy saving and seasonal efficiency: the winning features of the K Series heaters

### Comfort without competitors

Supply of heating output and ventilation is in proportion to the requirements of indoor space.

**Modulation of heat output and air flow rate** are controlled and managed by an electronic circuit board and a digital chronothermostat installed in the indoor area to be heated.

On the basis of the temperature set and the heating conditions of the area, the electronic system supplies the right amount of heat and provides exceptionally high efficiencies and improved comfort. During operation at full capacity, therefore, the heater is particularly efficient,

pleasant and quiet.

The graphic below shows this particular capacity to keep comfort comparing the indoor temperature of a room heated with an ON-OFF heater and with a K Series heater when the heat request is reduced.

Thanks to the heat and the fan modulation and to an electronic

system with a digital chronothermostat, the temperature is kept almost constant.

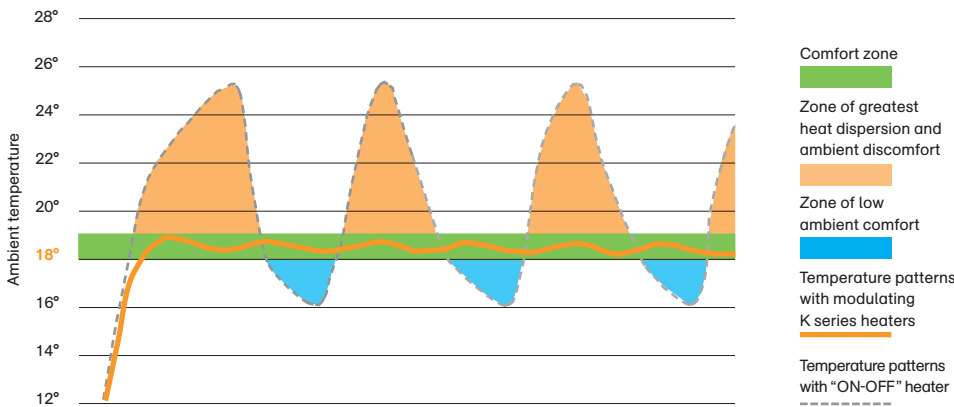

Digital chronothermostat, supplied as standard

### Energy savings and seasonal efficiency

K Series heaters have been designed to provide high thermal efficiency under all operational range. In fact, for most of the winter season, heat requirements are less than the maximum specified in the project and it is in these conditions that Robur gas fired unit heaters perform at their best.

Their efficiency, already a

remarkable 92% at maximum heat output, rises by 4 percentage points to 96.2% (see graph below). Furthermore, the modulation allows the amounts of on and off to be reduced and therefore increasing the efficiency of the overall system.

### Digital chronothermostat for regulation and control

The digital chronothermostat, supplied as standard with K Series gas fired heaters, offers important control functions, resulting in a more precise and economical use of the installation. With a simple connection via a shielded dual-conductor cable, it is possible to control the electronic circuit board of each gas unit heater to obtain the following functions:

- programmable timer for three separate temperature levels (comfort, reduced or freeze protection);
- winter operation in three selectable modes:
  - automatic: the heater adjusts the heating output and air flow rate to suit indoor temperature;
  - manual: the heater operates

- at one of 3 levels of heating output, which can be set manually;
  - anti-frost: the heater prevents the indoor temperature from falling below the freeze protection level set;
  - summer operation (ventilation only) with manual selection of ventilation speed;
  - operational and fault diagnostics, with warning signals and alarm reset.
- In addition, if more than one heater is installed in the same indoor space, it is possible to centralize the operation of all heaters, thus keeping unchanged the functions provided by the supplied chronothermostat.

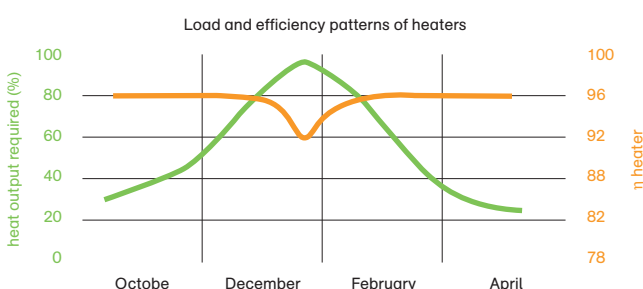



Suspended heaters with high-airflow rate designed for indoor installation free-blowing version.

## K Series heaters with axial fan



### Distinguishing characteristics

K Series heaters are available in the suspended version for indoor installation and are equipped with:

- flame modulation burner with complete gas/air pre-mixing. This specific burner has been manufactured to ensure constant, continuous and
- efficient modulation of heat output between 100% to 56%;
- axial fan with widened blades, for a greater air flow, controlled by a built-in electronic circuit board that regulates the fan speed for precise comfort control;
- air/flue ducts both 80 mm in diameter;
- advanced microprocessor controls modulate the heat input and regulate the fan speed;
- digital chronothermostat (supplied as standard) for regulation and control of the gas fired unit heater.

Examples of installation. K Series heaters are certified, together with the intake and exhaust ducts, sealing elements and Robur terminals, for type C installations (in which intake of combustion air and expulsion of exhaust gases take place externally) or type B installations (in which intake of combustion air occurs internally and expulsion of exhaust gases externally).



#### C 13 type

Room sealed combustion circuit appliance with inlet air supply and outlet of exhaust gases, either concentric or separated ducts on the same wall.



#### B 23 type

This appliance must be connected to a flue which draws the exhaust gases to the outside (on the wall or on the roof) of the room containing the appliance.



#### C 33 type

Room sealed combustion circuit appliance with inlet air supply and outlet of exhaust gases, either concentric or separated ducts on the same roof.



#### C 53 type

Room sealed combustion circuit appliance with inlet air supply and outlet of exhaust gases by using separated ducts and terminals on different walls.

#### C 63 type

Room sealed circuit appliance sold without the terminal or the combustion air supply and exhaust gases ducts.

			K 32	K 45	K 60	K 80	K 100
Heat input	maximum	kW	32.0	45.0	60.0	80.0	100.0
	minimum	kW	18.6	27.0	34.5	46.0	56.0
Nominal heat output	maximum	kW	29.6	41.6	55.2	73.6	92.0
	minimum	kW	17.7	25.8	33.0	44.2	53.9
Efficiency at heat input	maximum	%	92.5	92.5	92.0	92.0	92.0
	minimum	%	95.0	95.5	95.6	96.0	96.2
Gas consumption <sup>(1)</sup>	natural gas	m <sup>3</sup> /h	3.39	4.76	6.35	8.47	10.58
	LPG G30	kg/h	2.52	3.55	4.73	6.31	7.88
	LPG G31	kg/h	2.49	3.50	4.66	6.22	7.77
Air flow rate <sup>(2)</sup>	maximum	m <sup>3</sup> /h	2700	4000	5350	6300	8250
	minimum	m <sup>3</sup> /h	2.300	2.600	3.670	4.000	5.775
Temperature rise	at maximum speed	K	31.0	30.8	30.6	34.6	33.0
	at minimum speed	K	29.9	29.4	26.7	32.8	27.7
Gas connection		"F	3/4				
Air inlet pipe diameter		mm	80				
Exhaust air pipe diameter		mm	80				
Electrical supply			230 V 1N - 50 Hz				
Installed wattage		W	350	450	750	650	900
Air throw <sup>(3)</sup>		m	18	25	31	36	40
Recommended height of installation		m	2.5/3	2.5/3	3/3.5	3/3.5	3/4
Operating temperature range <sup>(4)</sup>		°C	0/35				
Sound pressure level at 6 metres	at maximum speed in open field	dB(A)	47	48	50	52	54
	at maximum speed in typical installation	dB(A)	59.0	60.0	61.5	63.0	65.5
	at minimum speed in typical installation	dB(A)	55.0	55.0	56.0	56.0	60.5
Weight		kg	55	65	75	98	120

<sup>(1)</sup> At 15 °C - 1013 mbar.

<sup>(2)</sup> At 20 °C - 1013 mbar.

<sup>(3)</sup> Throw for guidance only. Throw depends on height of building, mounting height to heater, room temperature and louvre setting.

<sup>(4)</sup> Indoor temperature of the installation location. The unit's internal components have been tested from 0 °C to 60 °C.

Due to continuous product innovation and development, Robur reserves the right to change product specification without prior notice.

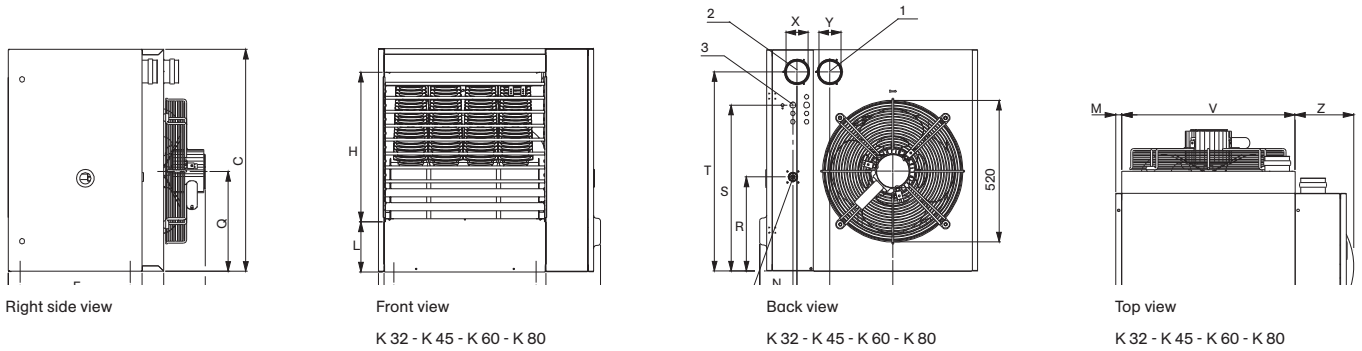

Right side view

Front view

Back view

Top view

K 32 - K 45 - K 60 - K 80

K 32 - K 45 - K 60 - K 80

K 32 - K 45 - K 60 - K 80

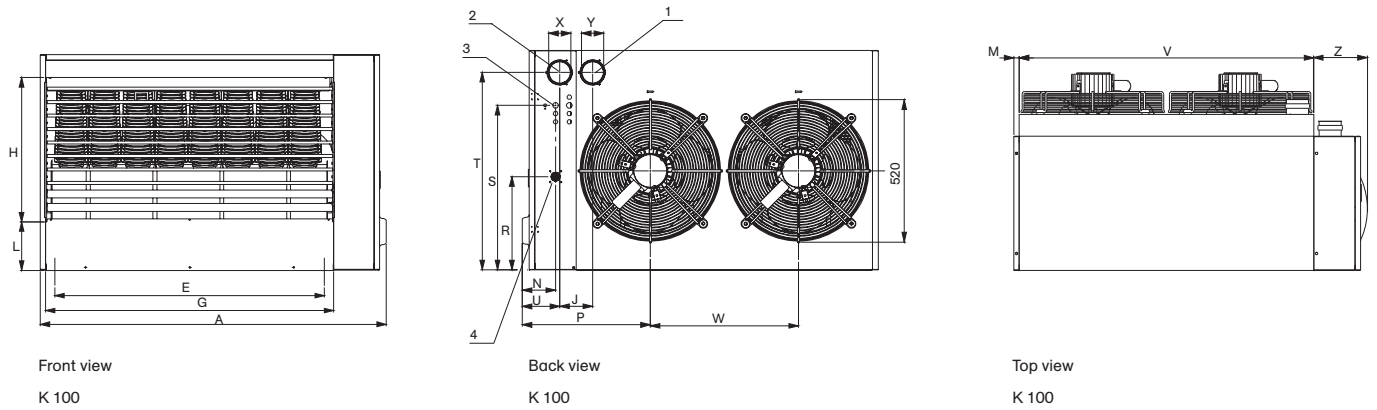

Front view

Back view

Top view

K 100

K 100

K 100

- 1 Flue
- 2 Air intake
- 3 Conduit entry for electrical connection
- 4 Gas supply

	A	B	C	D	E	F	G	H	I	J	L	M	N	P	Q	R	S	T	U	V	W	X	Y	Z
<b>K 32</b>	656	722	800	570	370	405	440	536	490	120	180	20	121	417	360	340	600	720	136	440	-	80	80	196
<b>K 45</b>	706	722	800	570	370	405	490	536	490	120	180	20	121	441	360	340	600	720	136	490	-	80	80	196
<b>K 60</b>	796	722	800	570	510	405	580	536	490	120	180	20	121	486	360	340	600	720	136	580	-	80	80	196
<b>K 80</b>	1097	722	800	570	810	405	880	536	490	120	180	20	121	637	401	340	600	720	136	880	-	80	80	196
<b>K 100</b>	1296	722	800	570	1010	405	1080	536	490	120	180	20	121	466	360	340	600	720	136	1080	540	80	80	196



Designed for ducted applications to provide heating and ventilation.

## K CM Series

heaters with centrifugal fan and mixing chamber

### Specific characteristics

Equipped with centrifugal fan and mixing chamber, the K CM heaters can provide heating and ventilation.

K CM Series heaters are fitted with:

- burner with complete gas/air pre-mixing. This specific burner is manufactured to guarantee a constant and efficient heat
- output (ON-OFF mode);
- belt driven centrifugal blowers, high pressure head and fixed airflow rate;
- mixing chamber consisting of:
  - fresh air and return air dampers;
  - filters fitted to both fresh air and return air (optional);
  - duct spigot on return air and fresh air.



Easier installation. The gas fired heaters are supplied with a base frame as standard which allows either four points suspension or floor mounting in a plant room. It makes transportation easy.

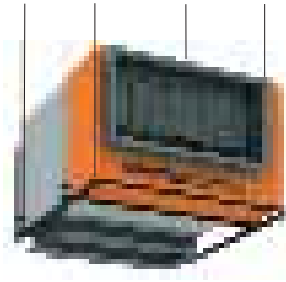

The gas fired unit heaters are provided as standard with a flange for the fitting of an anti-vibration joint which connects the heater to the duct system.

K CM units are fitted with a mixing box type cabinet complete with interlinked fresh air and return air dampers. Dampers may be either manually controlled or fitted with damper actuators.

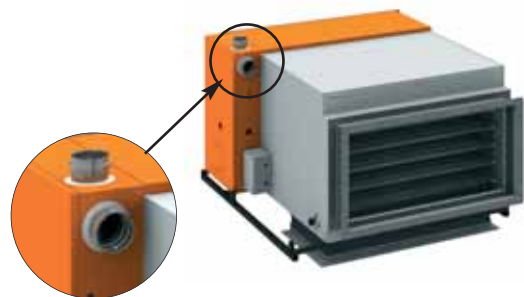

Balanced flue outlets are available as either roof outlets or to avoid roof penetration.

The units may be flued through the wall using wall outlet.

Extensions pipes are also available on request.

When the external exhaust terminal is fitted, care must be taken to ensure that it is sufficiently far from the intake grille of the mixing chamber, in order to prevent a partial intake of exhaust fumes towards the inside of the room to be heated.

		K 32CM	K 45CM	K 60CM	K 80CM	K 100CM	
Nominal heat input	kW	32	45.0	60.0	80.0	100.0	
Nominal heat output	kW	29.6	41.6	55.2	73.6	92.0	
Efficiency	%	92.5	92.5	92	92	92	
Nominal gas consumption <sup>(1)</sup>	natural gas	m <sup>3</sup> /h	3.39	4.76	6.35	8.47	10.58
	LPG G30	kg/h	2.52	3.55	4.73	6.31	7.88
	LPG G31	kg/h	2.49	3.50	4.66	6.22	7.77
Nominal air flow rate at maximum admitted pressure drop <sup>(2)</sup>	m <sup>3</sup> /h	2700	4150	5350	6300	8045	
Maximum available pressure head	without air filters	Pa	220	350	300	300	260
	with air filters fitted <sup>(3)</sup>	Pa	170	250	180	250	160
Temperature rise at nominal airflow rate	K	31.0	30.0	30.6	34.6	33.9	
Gas connection	"F	3/4					
Air inlet pipe diameter	mm	80					
Exhaust air pipe diameter	mm	80					
Electrical voltage		230 V 1N - 50 Hz		400 V 3N - 50 Hz			
Installed wattage (with reference to nominal airflow rate)	kW	1.1	1.7	1.6	2.3	2.3	
Operating temperature range <sup>(4)</sup>	°C	0/35					
Weight	kg	105	153	166	205	260	

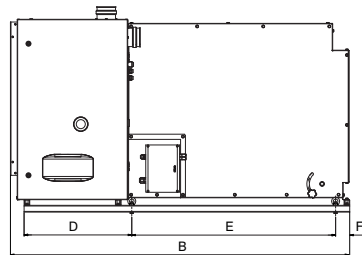

Right side view

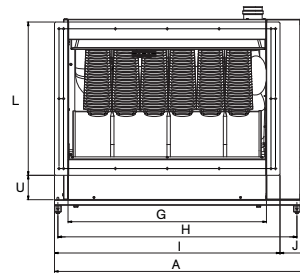

Front view

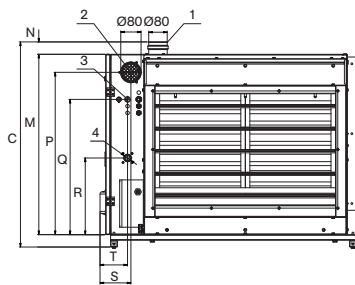

Back view

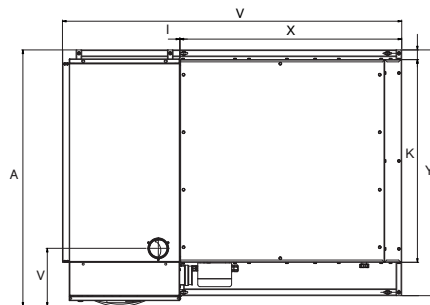

Top view

- 1 Flue
- 2 Air intake
- 3 Conduit entry for electrical connection
- 4 Gas supply

	A	B	C	D	E	F	G	H	K	I	J	L	M	N	P	Q	R	S	T	U	V	W	X	Y
K 32CM	697	1505	910	478	904	62	440	620	459	560	135	680	800	55	720	600	340	135	120	108	255	1505	984	650
K 45CM	747	1505	910	478	904	62	490	670	509	610	135	680	800	55	720	600	340	135	120	108	255	1505	984	700
K 60CM	835	1505	910	478	904	62	578	760	600	700	135	680	800	55	720	600	340	135	120	108	255	1505	984	790
K 80CM	1137	1505	910	478	904	62	880	1060	899	1000	135	680	800	55	720	600	340	135	120	108	255	1505	984	1090
K100CM	1335	1505	910	478	904	62	1078	1250	1100	1200	135	680	800	55	720	600	340	135	120	108	255	1505	984	1290

<sup>(1)</sup> At 15 °C - 1013 mbar.

<sup>(2)</sup> At 20 °C - 1013 mbar.

<sup>(3)</sup> Class G3 air filters (optional).

<sup>(4)</sup> Indoor temperature of the installation location. The unit's internal components have been tested from 0 °C to 60 °C.

Due to continuous product innovation and development, Robur reserves the right to change product specification without prior notice.

## Accessories

The installation of K and K CM heaters is completed with a range of accessories that makes their fitting and operation easier.

### Standard accessories



#### Remote control

Remote control with the following function:

- lock-out warning lamp;
- reset button;
- summer/winter switch.

### Accessories and flue components

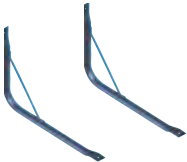

#### Tubular support bracket for K Series, axial version

Extremely easy to install, it is suitable for all models and is supplied with ties-rods, bolts and washers to anchor to the wall.

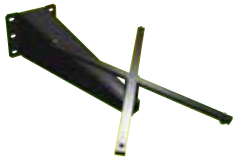

#### Revolving wall support bracket for K Series, axial version

This allows for an easy and correct installation of the gas unit heater. Complete with external counterplate.



#### Ducts for separate exhaust outlet

Additional flue and combustion air pipes may be added and are all available on request.



#### Double external terminal

The new external terminal for 80 mm diameter (separate) inlet and outlet ducts is a Robur personalized accessory. In addition to its modern design, the extremely limited projection (4.3 cm from the wall) is another of its exclusive characteristics. The kit also includes the external terminal and fitting and fixing elements.



#### External terminal

External stainless steel terminal, suitable for use with 110 - 130 mm (inlet and outlet air) diameter ducts with wall outlet.



#### Roof and wall concentric flue terminal kits

A concentric terminal must be used for balanced flue applications. These are available for either roof or wall outlet.



#### Class G3 filter kit for K CM

Consisting of filters in class G3, ready to be inserted in the seats specifically provided on the internal and external air intake inlets of the mixing chamber.

**Note:** To choose the most appropriate components, please consult the guide to choosing air intake and exhaust ducts for K series heaters.



High performance and low NOx emissions. Suspended free-blowing heaters, available in 7 different outputs from 21 to 92 kW also with vertical flowdown.

## F Series

### Distinguishing characteristics

- Pre-mixing multigas burner in stainless steel with combustion efficiency of 92%.
- Extremely low NOx contents of exhaust gases, for reduced environmental impact.
- Intake and exhaust ducts both only 80 mm in diameter, to make installation easier.
- Axial fan for free-blowing operation.

### Ideal applications

- Their wall-mounted position and reduced overall dimensions mean that F series heaters can heat large buildings too, including:
- industrial premises and workshops;
  - laboratories;
  - warehouses and storage facilities;
  - supermarkets and showrooms.

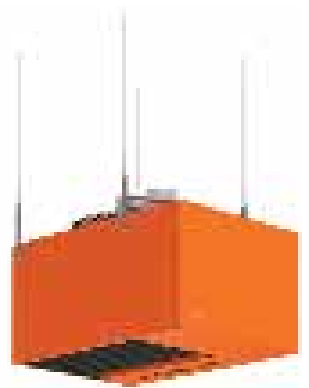

Examples of installation. European norms classify gas appliance depending on the type of installation of combustion air inlet and exhaust duct.

F gas unit heaters are certified for the following types of installation using the ducts, components and terminals proposed by Robur.

Robur offers a complete range of accessories for B-type and C-type installations. All components are equipped with gaskets and hose clamps.

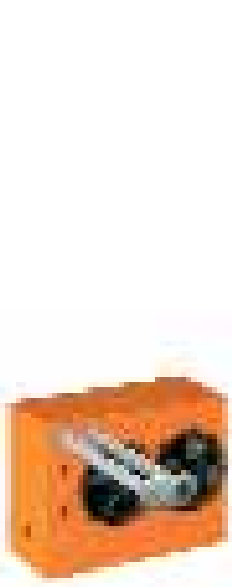

**C 13 type**

Room sealed combustion circuit appliance with inlet air supply and outlet of exhaust gases, either concentric or separated ducts on the same wall.



**C 13 type**

This appliance must be connected to a flue which draws the exhaust gases to the outside (on the wall or on the roof) of the room containing the appliance.

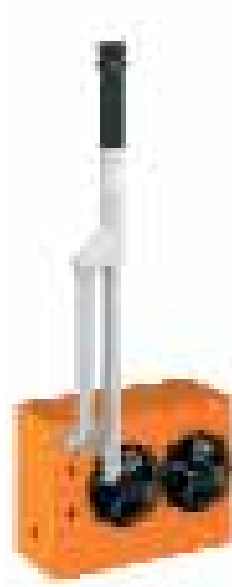

**C 33 type**

Room sealed combustion circuit appliance with inlet air supply and outlet of exhaust gases, either concentric or separated ducts on the same roof.



**C 53 type**

Room sealed combustion circuit appliance with inlet air supply and outlet of exhaust gases by using separated ducts and terminals on different walls.

**C 63 type**

Room sealed circuit appliance sold without the terminal or the combustion air supply and exhaust gases ducts.

**B 23 type**

Open circuit with combustion air intake in heated environment and wall- or roof-mounted exhaust outlet.

		F1 21	F1 31	F1 41	F1 51	F2 60	F2 80	F2 100	
Nominal heat input	kW	23.08	30.77	37.15	48.35	60.0	80.0	100.0	
Nominal heat output	kW	21.0	28.0	33.8	44.0	55.2	73.6	92.0	
Efficiency	%	91.0	91.0	91.0	91.0	92.0	92.0	92.0	
Nominal gas consumption <sup>(1)</sup>	natural gas	m <sup>3</sup> /h	2.43	3.25	3.93	5.11	6.35	8.47	10.58
	LPG G30	kg/h	1.80	2.42	2.93	3.81	4.73	6.31	7.88
	LPG G31	kg/h	1.78	2.38	2.87	3.74	4.66	6.22	7.77
Nominal air flow <sup>(2)</sup>	m <sup>3</sup> /h	2000	2700	3400	4200	5350	6300	8250	
Temperature rise	K	31.1	30.7	29.5	31.0	30.6	34.6	33.0	
Gas connection	"F	3/4							
Air inlet pipe diameter	mm	80							
Exhaust air pipe diameter	mm	80							
Electrical voltage	230V 1N - 50Hz								
Installed wattage	W	260	400	400	450	750	650	900	
Air throw <sup>(3)</sup>	m	14	16	20	22	31	36	40	
Recommended installation height	m	2.5/3	2.5/3	2.5/3	3/3.5	3/3.5	3/3.5	3/4	
Operating temperature range <sup>(4)</sup>	°C	0/35							
Sound pressure level at 6 metres	in open field	dB(A)	41	43	44	46	50	52	54
	in typical installation	dB(A)	53	55	56	57	61.5	63	65.5
Weight	kg	55	59	68	80	75	98	120	

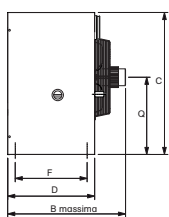

Right side view  
F1 21 - F1 31 - F1 41 - F1 51

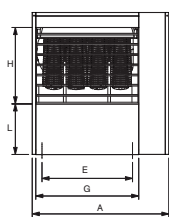

Front view  
F1 21 - F1 31 - F1 41 - F1 51

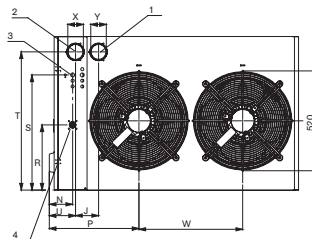

Back view

- 1 Flue
- 2 Air intake
- 3 Entry for electrical connection
- 4 Gas supply

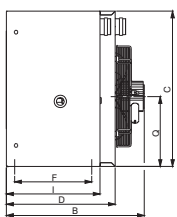

Right side view  
F2 60 - F2 80 - F2 100

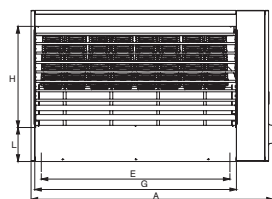

Front view  
F2 60 - F2 80 - F2 100

	A	B	C	D	E	F	G	H	I	J	L	N	P	Q	R	S	T	U	V	W	X	Y	Z
F1 21	630	640	800	490	370	405	440	430	-	120	285	95	390	435	340	600	720	90	3/4"	-	80	80	355
F1 31	630	640	800	490	370	405	440	430	-	120	285	95	390	435	340	600	720	90	3/4"	-	80	80	355
F1 41	770	670	800	490	510	405	580	430	-	120	285	95	460	435	340	600	720	90	3/4"	-	80	80	410
F1 51	880	700	800	490	620	405	690	430	-	120	285	95	515	435	340	600	720	90	3/4"	-	80	80	410
F2 60	796	722	800	570	510	405	580	536	490	120	180	121	486	360	340	600	720	136	580	-	80	80	520
F2 80	1.097	722	800	570	810	405	880	536	490	120	180	121	637	401	340	600	720	136	880	-	80	80	520
F2 100	1.296	722	800	570	1.010	405	1.080	536	490	120	180	121	466	360	340	600	720	136	1.080	540	80	80	520

<sup>(1)</sup> At 15 °C - 1013 mbar.

<sup>(2)</sup> At 20 °C - 1013 mbar.

<sup>(3)</sup> Throw for guidance only. Throw depends on height of building, mounting height to heater, room temperature and louvre setting.

<sup>(4)</sup> Indoor temperature of the installation location. The unit's internal components have been tested from 0 °C to 60 °C.

Due to continuous product innovation and development, Robur reserves the right to change product specification without prior notice.

### F series with vertical downflow

Gas fired unit heaters F series are available also with vertical downflow units that direct the warm air exactly where it is needed.

These models have been designed and are particularly suitable for the direct heating in a wide range of applications - industrial and commercial premises, retail, sports and leisure, warehouses, logistics and distribution centres.

They are ideally suited for distributing heat into those often hard to get to aisles in premises containing floor-to-ceiling racking.

Vertical downflow gas fired unit heaters have to be suspended on the upper part of the building within the roof and fixed to the ceiling or to support beams well clear of the production lines. Installing F with vertical downflow within the roof space the recirculation air pattern reduces the floor to ceiling heat gradient and they also work as a destratification fan.

These gas fired unit heaters, due to their specific use, are different to the standard version, since:

- They're equipped with 4 suitable support brackets for the vertical installation and with horizontal louvers. Vertical louvers are highly recommended.
- They have limit thermostat and internal electrical devices in suitable position for the vertical downflow functioning.
- There are equipped with a door support system to permit a correct and safe maintenance service with open door.
- They use fans suitable for vertical downflow installation.

These gas fired unit heaters, available both with axial and centrifugal fan, could be equipped in centrifugal fan version with accessories for full fresh air or re-circulation or a combination of fresh and recirculated air: air mixing chambers, regulation dampers, air filters, anti-vibration joints for ducting systems.





To heat several rooms with a single appliance. Suspended gas fired heaters with centrifugal fan available in 4 models from 21 to 73.6 kW.

## F C Series heaters with centrifugal fan

### Distinguishing characteristics

- Centrifugal fan designed for ducting application.
- Flange duct outlet suitable to be connected to an anti-vibration joint (optional). Duct system will be sized according to the available pressure head of the model of heater.
- Burner with total air pre-mixing and low NOx emissions.
- Heating efficiency up to 92%.

- Air intake and exhaust outlet pipes both 80 mm in diameter, ensuring quick and easy installation.

### Ideal applications

- Changing rooms.
- Rooms used as offices, for meetings and for services.
- Restaurants, bars and shops.



		F1 21C	F1 41C	F1 51C	F2 80C	
Nominal heat input		kW	23.08	37.15	48.35	80.0
Nominal heat output		kW	21.0	33.8	44.00	73.6
Efficiency		%	91	91	91	92
Nominal gas consumption <sup>(1)</sup>	natural gas	m <sup>3</sup> /h	2.43	3.93	5.12	8.47
	LPG G30	kg/h	1.80	2.93	3.81	6.31
	LPG G31	kg/h	1.78	2.87	3.73	6.22
Air flow <sup>(2)</sup>	with free outlet	m <sup>3</sup> /h	2500	3500	4000	7800
	at maximum admissible pressure drop	m <sup>3</sup> /h	2000	2600	2800	6300
Maximum available pressure head		Pa	110	120	180	110
Gas connection		"F	3/4			
Air inlet pipe diameter		mm	80			
Exhaust air pipe diameter		mm	80			
Electrical supply			230 V 1N - 50 Hz			
Installed wattage		W	510	650	1100	1200
Dimensions	width	mm	630	770	770	1097
	height	mm	800	800	800	800
	depth	mm	990	1030	1030	1110
Weight		kg	66	82	87	123

<sup>(1)</sup> At 15 °C - 1013 mbar.

<sup>(2)</sup> At 20 °C - 1013 mbar.

Due to continuous product innovation and development, Robur reserves the right to change product specification without prior notice.

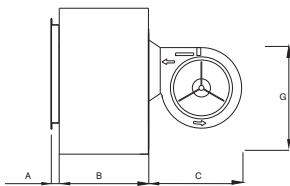

Side view

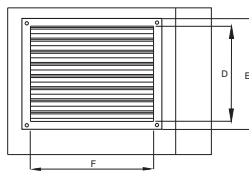

Front view

	A	B	C	D	E	F	G
F1 21C	50	490	500	500	580	500	650
F1 41C	50	490	540	500	580	600	650
F1 51C	50	490	540	500	580	600	650
F2 80C	50	570	540	536	616	1000	650

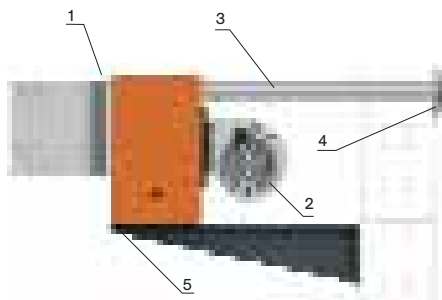

- 1 Anti-vibration joint
- 2 Centrifugal fan
- 3 Air intake and exhaust pipes Ø 80 mm
- 4 External wall terminal
- 5 Wall support bracket

The F C heaters (fig. 1) could be supplied by the following accessories:

- mixing chamber kit (fig. 2);

- regulation damper;
- air filters;
- filter holder kit;
- antivibration joints;

- base frame;
  - support bracket.
- All these components can be installed on the back

or on the bottom side of the chamber (fig. 3).



Fig. 1

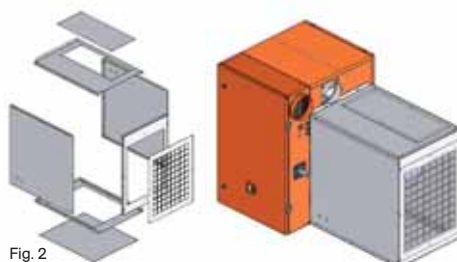

Fig. 2

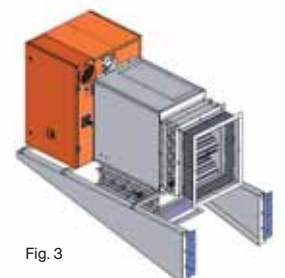

Fig. 3

## Accessories

F heaters have many options to simplify installation operations and to tailor their operation to meet the clients operating needs.

### Standard accessories



#### Remote control (supplied as standard)

Remote control with the following functions:

- lock-out warning lamp;
- reset button;
- summer/winter switch.

### Accessories, controls and flue components



#### Room thermostat

Electromechanical thermostat with ON-OFF switch.  
Available also in IP 55 waterproof version.



#### Analogue programmable heater timer

Equipped with a quartz programmable timer with mechanical switching and a thermostat with two independent control temperatures.  
Programming is on a weekly basis.



#### Integrated digital programmable timer

A command that brings together all of the control and programming functions of the heater in a single device: programmable timer, electronic thermostat, summer/winter switch reset button and lock-out warning lamp.

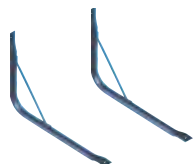

#### Tubular support bracket for F Series

Extremely easy to install, it is suitable for all models and is supplied with ties-rods, bolts and washers to anchor to the wall.

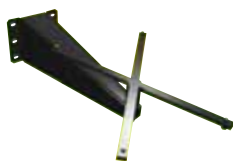

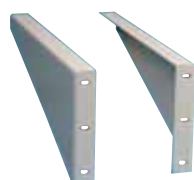

#### Revolving wall support bracket for F Series

This allows for an easy and correct installation of the gas unit heater.  
Complete with external counterplate.



#### Support bracket for F C Series

This bracket allows indoor installation of heaters equipped with a centrifugal fan.

	<p><b>Ducts for separate exhaust outlet</b></p>	<p>Additional flue and combustion air pipes may be added and are all available on request.</p>
	<p><b>Double external terminal</b></p>	<p>The new external terminal for 80 mm diameter (separate) inlet and outlet ducts is a Robur personalized accessory. In addition to its modern design, the extremely limited projection (4.3 cm from the wall) is another of its exclusive characteristics. The kit also includes the external terminal and fitting and fixing elements.</p>
	<p><b>Adjustable vertical louvres</b></p>	<p>The louvres allow the airflow to be diffused in the desired direction, extending the air throw zone of the appliance, and also for obstacles (such as columns, machine tools, etc.), for which direct heating is not appropriate, to be avoided.</p>

**Optional for F C**

	<p><b>Mixing chamber kit</b></p>	
	<p><b>Filter holder kit</b></p>	
	<p><b>Air filter G3 class</b></p>	
	<p><b>Regulation damper</b></p>	
	<p><b>Anti vibration joint</b></p>	
	<p><b>Base frame</b></p>	

**Note:** For the correct combination and specific means of use of the accessories, consult the specific technical documentation.



Technology and design come together in a single unit.  
Suspended gas fired heaters with an innovative design,  
available in 3 models with flame modulation, from 19.35 to 44.5 kW.

## Evoluzione Series

### Distinguishing characteristics

- Suspended gas fired heaters with a modern, elegant design.
- Modulating burner and fan at 2 levels, automatically or manually.
- Ventilation system carefully designed to obtain reduced noise emissions: 36 dB (A) (minimum value for E 32 model in free field).
- Adjustable aluminium louvers

for directing airflow as desired.

### Ideal applications

Evoluzione has been designed to take its place gracefully in medium-to-large spaces, thanks to its modern design, which makes it particularly suitable for the heating of:

- exhibitions and showrooms;
- gyms and fitness centres;
- supermarkets and commercial settings.



## The winning features of Evoluzione heaters: optimal comfort and maximum savings.

Evoluzione is a suspended gas fired heater with an automatic heat output modulation system that allows the desired ambient temperature to be reached rapidly and kept constant, automatically modulating the heat output and air flow rate on two levels.

The heat output by Evoluzione is reduced by approximately 20% (by means of the integrated or thermostated control) according to temperature patterns inside the heated environment, or manually (when the basic control is used). This means that, with

constant efficiency, the desired ambient temperature can be maintained, gas consumption reduced and noise levels further diminished.

The adoption of a multigas burner with total air pre-mixing means that combustion can be optimised, with efficiency that remains extremely high even during reduced-power operation.

When the desired temperature is set at 20 °C with a differential of 1 °C (as shown in the graph below), Evoluzione supply maximum power up to 19 °C, and then automatically reduces

the heat output (and therefore consumption), and the air flow rate.

This automatic modulation system ensures the level of comfort desired with maximum savings and minimum noise levels.

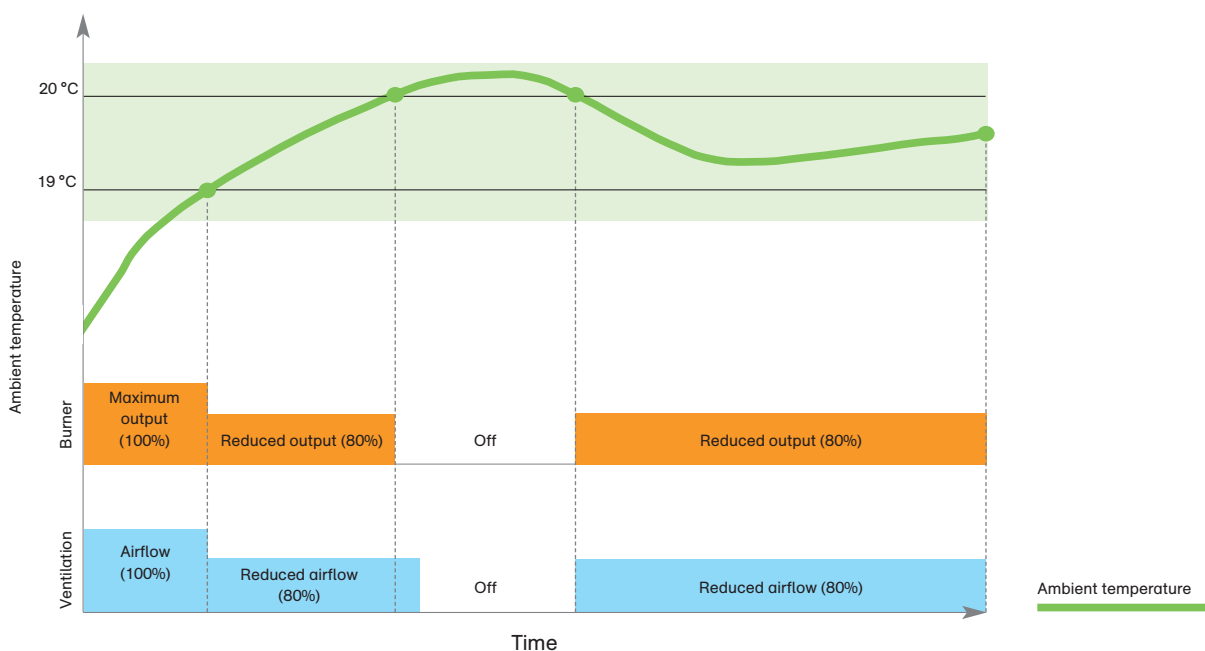

Examples of installation. Evoluzione heaters are certified, together with the intake and exhaust ducts, sealing elements and Robur terminals, for type C installations (in which intake of combustion air and expulsion of exhaust gases take place externally) or type B installations (in which intake of combustion air occurs internally and expulsion of exhaust gases externally).



#### C 13 type

Room sealed combustion circuit appliance with inlet air supply and outlet of exhaust gases, either concentric or separated ducts on the same wall.

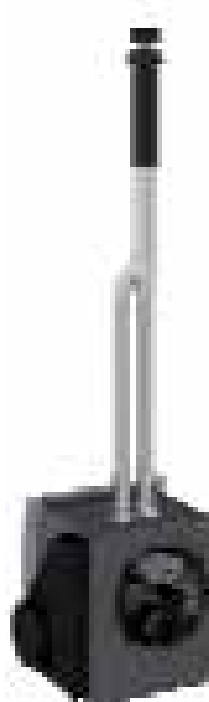

#### C 33 type

Room sealed combustion circuit appliance with inlet air supply and outlet of exhaust gases, either concentric or separated ducts on the same roof.

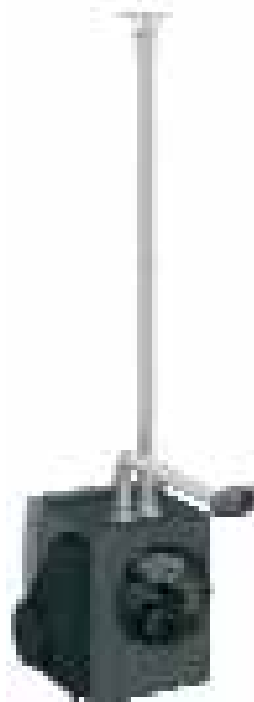

#### C 53 type

Room sealed combustion circuit appliance with inlet air supply and outlet of exhaust gases by using separated ducts and terminals on different walls.

#### C 63 type

Room sealed circuit appliance sold without the terminal or the combustion air supply and exhaust gases ducts.

#### B 23 type

This appliance must be connected to a flue which draws the exhaust gases to the outside (on the wall or on the roof) of the room containing the appliance.

		E 32	E 43	E 52	
Nominal heat input		kW	26.0	37.15	48.35
Nominal heat output	nominal	kW	24.2	34.2	44.5
	reduced	kW	19.35	27.40	35.60
Efficiency		%	93	92	92
Nominal gas consumption <sup>(1)</sup>	natural gas	m <sup>3</sup> /h	2.75	3.93	5.11
	LPG G30	kg/h	2.05	2.93	3.81
	LPG G31	kg/h	2.01	2.9	3.74
Reduced gas consumption <sup>(1)</sup>	natural gas	m <sup>3</sup> /h	2.20	3.15	4.09
	LPG G30	kg/h	1.64	2.34	3.05
	LPG G31	kg/h	1.61	2.30	2.99
Nominal air flow <sup>(2)</sup>	at maximum speed	m <sup>3</sup> /h	2300	3400	4200
	at minimum speed	m <sup>3</sup> /h	1900	2700	3400
Temperature rise	at maximum speed	K	31.2	29.4	31.0
	at minimum speed	K	30.2	29.8	30.7
Gas connection		"F	3/4		
Air inlet pipe diameter		mm	80		
Exhaust air pipe diameter		mm	80		
Electrical voltage			230 V 1N - 50 Hz		
Installed wattage		W	250	350	420
Air throw at maximum speed <sup>(3)</sup>		m	14	20	22
Recommended installation height		m	2.5/3	2.5/3	3/3.5
Operating temperature range <sup>(4)</sup>		°C	0/35		
Sound pressure level at maximum speed at 6 metres	in open field	dB(A)	38	40	42
	in typical installation	dB(A)	48	52	56
Sound pressure level at 6 metres	in open field	dB(A)	36	37	38
	in typical installation	dB(A)	45	47	51
Weight		kg	60	66	74

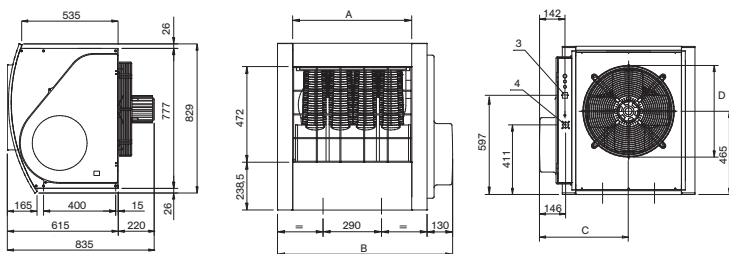

Right side view

Front view

Back view

E 32 - E 43 - E 52

- 1 Flue
- 2 Air intake
- 3 Conduit entry for electrical connection
- 4 Gas supply

	A	B	C	D
E 32	474	755	418	460
E 43	591	872	477	520
E 52	709	990	536	520

<sup>(1)</sup> At 15 °C - 1013 mbar.

<sup>(2)</sup> At 20 °C - 1013 mbar.

<sup>(3)</sup> Throw for guidance only. Throw depends on height of building, mounting height to heater, room temperature and louvre setting.

<sup>(4)</sup> Indoor temperature of the installation location. The unit's internal components have been tested from 0 °C to 60 °C.

Due to continuous product innovation and development, Robur reserves the right to change product specification without prior notice.

## Accessories

Evoluzione Type heaters have a wealth of accessories to simplify and speed up installation operations and to tailor the installation to the requirements of the spaces to be heated.

### Controls

	<p><b>Basic control</b></p>	<p>The simplest of the command options for Evoluzione Series. It allows summer/winter operation and manual switching of the heater between "maximum" and "economy" modes, it gives a warning if the operation of the appliance is blocked, and allows it to be reset. It is not possible to use the function of automatic modulation.</p>
	<p><b>Room thermostat</b></p>	<p>Of the electromechanical type with ON-OFF switch, necessary for the control of heater operation when the basic command is used.</p>
	<p><b>Thermostated control with temperature sensor</b></p>	<p>The thermostat performs all of the functions of the integrated command with the exception of timer programming. The temperature sensor, supplied with the command, can also be installed remotely (at a distance of up to 100 metres).</p>
	<p><b>Integrated control and IP55 sealed integrated command with temperature sensor</b></p>	<p>These commands allow operation and programming of the individual Evoluzione Series heaters to be controlled remotely. With them it is possible to program switch-on of the heater on a weekly or daily basis, control the temperature of the room, set a minimum temperature (freeze protection), switch from summer to winter operation, and reset the appliance if required. The temperature sensor, supplied with the command, can also be installed remotely (at a distance of up to 100 metres).</p>
	<p><b>Expansion module</b></p>	<p>Used with the thermostated command or integrated command, with the expansion module it is possible to control up to 3 heaters simultaneously. In addition, several expansion modules can be connected to each other to manage up to 150 heaters.</p>

Accessories and flue components

	<p><b>Upper support bracket with condensate separator and air intake/exhaust outlet duct connector kit</b></p>	<p>To support the heater from above, when the exit of the air intake and exhaust outlet ducts is roof- or wall-mounted, but far from the heater. The bracket is supplied complete with air intake/exhaust outlet duct connector kit, for connecting air intake and exhaust outlet ducts (with access hole for checks) whenever Robur support brackets are not used. Moreover, the condensate separator, necessary for preventing any condensate that has accumulated from entering the heater, is also supplied.</p>
	<p><b>Revolving wall support bracket for Evoluzione Series with condensate separator and air intake/exhaust outlet duct connector kit</b></p>	<p>This allows for an easy and correct installation of the gas unit heater. Complete with external counterplate. The bracket is supplied complete with air intake/exhaust outlet duct connector kit, for connecting air intake and exhaust outlet ducts (with access hole for checks) whenever Robur support brackets are not used. Moreover, the condensate separator, necessary for preventing any condensate that has accumulated from entering the heater, is also supplied.</p>
	<p><b>Ducts for separate exhaust outlet</b></p>	<p>Additional flue and combustion air pipes may be added and are all available on request.</p>
	<p><b>Double external terminal</b></p>	<p>The new external terminal for 80 mm diameter (separate) inlet and outlet ducts is a Robur personalized accessory. In addition to its modern design, the extremely limited projection (4.3 cm from the wall) is another of its exclusive characteristics. The kit also includes the external terminal and fitting and fixing elements.</p>
	<p><b>Roof and wall concentric flue terminal kits</b></p>	<p>A concentric terminal must be used for balanced flue applications. These are available for either roof or wall outlet.</p>
	<p><b>Condensate separator</b></p>	<p>Installed on the exhaust outlet duct, it is necessary as it prevents any condensate that has accumulated from entering the heater. To be fitted when Robur support brackets are not fitted.</p>
	<p><b>Air intake/exhaust outlet duct connector kit</b></p>	<p>For connecting air intake and exhaust outlet ducts (with access hole for checks) whenever Robur support brackets are not used.</p>
	<p><b>Louvres for heat direction adjustment (spare parts)</b></p>	<p>Adjustable aluminium louvres for directing airflow as desired: sideways, to the right or left, downwards or to the centre of the room to be heated. The louvres, supplied in kits of 20 pieces, are applied to the front grille of the heater.</p>

**Note:** For the correct combination and specific means of use of the accessories, consult the specific technical documentation.



Maximum range of products with a high level of reliability. Gas fired unit heaters with atmospheric burner, available in 19 models from 12.8 to 63.8 kW.

## M Series

### Distinguishing characteristics

- Available in 19 models with outputs from 12.8 kW to 63.8 kW, to satisfy all needs. The **2v** with a 2 stage burner are also equipped with a 2 speed fan, ideal for low noise level applications. On request it is available also the **inox version**, particularly qualified for installations in greenhouses, cattle-breeding farms, food transformation and conservation storehouses and in all the environments with high levels of air acidity and humidity.

**M** and **M inox** models are supplied with remote controls with lockout warning lamp and reset button.

**M 2v** models are also supplied with summer/winter switch and speed change controller.

- The simplicity and reliability of M series heaters provide a superior price/performance ratio in comparison with other heating systems.

### Ideal applications

Thanks to the wide range to choose from, M heaters are ideal for heating all medium-to-large buildings, such as:

- industrial premises and workshops;
- laboratories;
- warehouses and storage facilities;
- supermarkets and showrooms.
- greenhouses and livestock facilities.



Examples of installation. M Series heaters represent the ideal solution for any type of plant configuration and are certified for different types of installation.



**C 12 type (split ducts)**

Sealed circuit with combustion air intake and exhaust outlet with dual wall-mounted ducts.



**C 12 type (coaxial ducts)**

Sealed circuit with combustion air intake and exhaust outlet with coaxial wall-mounted duct.

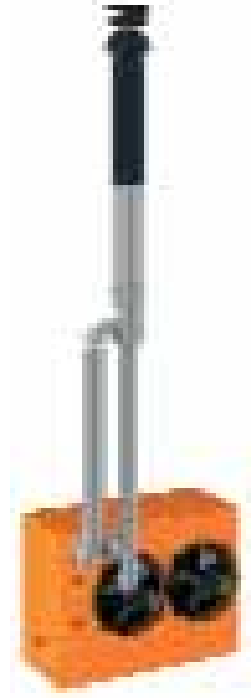

**C 32 type**

Sealed circuit with combustion air intake and exhaust outlet with coaxial or (split) roof-mounted duct.

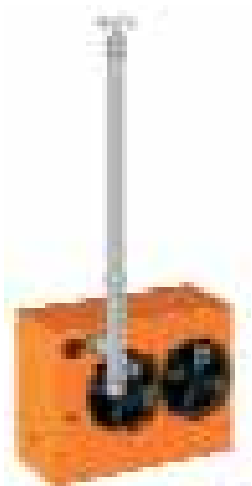

**B 22 (roof-mounted)**

Open circuit with combustion air intake in heated environment and roof-mounted exhaust outlet.

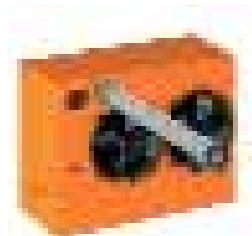

**B 22 type (wall-mounted)**

Open circuit with combustion air intake in heated environment and wall-mounted exhaust outlet.

			M 20	M 25	M 30	M 35	M 40	M 50	M 60	M 20 2v	M 25 2v	M 30 2v	M 50 2v	M 60 2v
Nominal heat input		kW	20.6	28.8	34.8	42.2	48.2	57.3	72.5	20.6	28.8	34.8	57.3	72.5
Heat output	nominal	kW	18.3	25.5	30.7	37.4	42.5	50.7	63.8	18.3	25.5	30.7	50.7	63.8
	reduced	kW	-	-	-	-	-	-	-	12.8	17.7	21.1	36.0	42.0
Efficiency		%	88.8	88.5	88.2	88.6	88.2	88.5	88.0	88.8	88.5	88.2	88.5	88.0
Nominal gas consumption <sup>(1)</sup>	natural gas	m <sup>3</sup> /h	2.18	3.04	3.68	4.46	5.10	6.06	7.67	2.18	3.04	3.68	6.06	7.67
	LPG G30	kg/h	1.62	2.27	2.74	3.32	3.80	4.52	5.72	1.62	2.27	2.74	4.52	5.72
	LPG G31	kg/h	1.62	2.27	2.74	3.32	3.80	4.52	5.72	1.62	2.27	2.74	4.52	5.72
Air flow <sup>(2)</sup>	nominal	m <sup>3</sup> /h	1700	2350	3000	3400	3750	4700	6200	1700	2350	3000	4700	6200
	reduced	m <sup>3</sup> /h	-	-	-	-	-	-	-	1300	1800	2300	3500	4600
Temperature rise		K	32.0	32.0	30.3	32.6	33.6	32.0	30.5	32.0	32.0	30.3	32.0	30.5
Gas connection		"M	1/2	1/2	1/2	1/2	1/2	3/4	3/4	1/2	1/2	1/2	3/4	3/4
Air inlet pipe diameter <sup>(3)</sup>		mm	130											
Exhaust air pipe diameter <sup>(3)</sup>		mm	110											
Electrical supply			230 V 1N - 50 Hz											
Installed wattage		W	340	340	340	340	400	620	620	340	340	340	620	620
Air throw <sup>(4)</sup>		m	12	15	18	20	21	23	25	12	15	18	23	25
Recommended installation height		m	2.5	2.5/3	2.5/3	2.5/3	2.5/3	2.5/3	3/3.5	2.5	2.5/3	2.5/3	2.5/3	3/3.5
Operating temperature range <sup>(5)</sup>		°C	0/35											
Sound pressure level at 6 metres	in open field	dB(A)	41	43	44	44	45	45	47	41	43	44	45	47
	in typical installation	dB(A)	53	55	56	56	57	58	59	53	55	56	58	59
	in typical installation at reduced speed	dB(A)	-	-	-	-	-	-	-	44	45	47	47	49
Weight		kg	55	59	68	80	80	90	108	55	59	68	90	108

Note: Data for the M Type is also valid for the Inox (stainless steel) version.

<sup>(1)</sup> A 15 °C - 1013 mbar.

<sup>(2)</sup> A 20 °C - 1013 mbar.

<sup>(3)</sup> Nominal diameter of rigid pipe to be inserted into specific cylindrical housing.

<sup>(4)</sup> Values measured in free field; in actual installation heat flow may reach significantly greater distances than the value declared above (depending on height, installation environment and thermal insulation of the area covered).

<sup>(5)</sup> Indoor temperature of the installation location. The unit's internal components have been tested from 0 °C to 60 °C.

Due to continuous product innovation and development, Robur reserves the right to change product specification without prior notice.

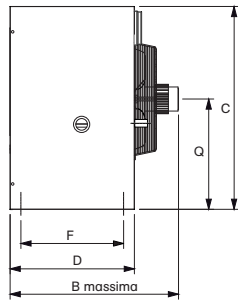

Right side view

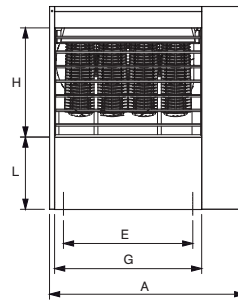

Front view

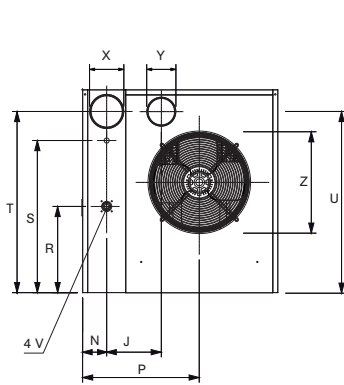

Back view

M 20 - M 25 - M 30 - M 35 - M 40

M 20 2v - M 25 2v - M 30 2v

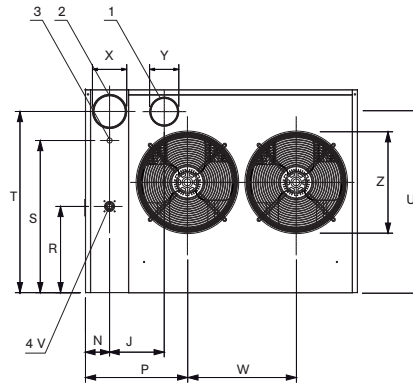

Back view

M 50 - M 60

M 50 2v - M 60 2v

- 1 Flue
- 2 Air intake
- 3 Conduit entry for electrical connection
- 4 Gas supply

	A	B	C	D	E	F	G	H	J	L	N	P	Q	R	S	T	U	V	W	X	Y	Z
M 20 - 20 2v	630	640	800	490	370	405	440	430	215	285	95	390	435	340	600	715	714	1/2	-	133	113	355
M 25 - 25 2v	630	640	800	490	370	405	440	430	215	285	95	390	435	340	600	715	714	1/2	-	133	113	355
M 30 - 30 2v	770	670	800	490	510	405	580	430	215	285	95	460	435	340	600	715	714	1/2	-	133	113	410
M 35	880	670	800	490	620	405	690	430	215	285	95	515	435	340	600	715	714	1/2	-	133	113	410
M 40	880	700	800	490	620	405	690	430	215	285	95	515	435	340	600	715	714	1/2	-	133	113	410
M 50 - 50 2v	1070	640	800	490	810	405	880	430	215	285	95	398	435	340	600	715	714	3/4	432	133	113	355
M 60 - 60 2v	1270	670	800	490	1010	405	1080	430	215	285	95	468	435	340	600	715	714	3/4	432	133	113	410



Ducting and changing the air with an air-to-air system.  
Gas fired unit heaters with atmospheric burner and centrifugal fan,  
available in 3 models from 18.3 to 63.8 kW.

## M C Series with centrifugal fan

### Distinguishing characteristics

- Centrifugal fan design for ducting applications.
- Available in 3 models, from 18.3 to 63.8 kW.
- Designed to be equipped with a back intake chamber applied by a regulation damper and air filters.
- Aluminium heat exchanger with double vertical and horizontal finning.

### Ideal applications

- The great reliability of the M C heaters makes possible air-to-air heating for:
- medium-large areas where air renew is required;
  - offices, changing rooms and other rooms where is required a ducted plant.



		M 20C	M 30C	M 60C	
Nominal heat input		kW	20.6	34.8	72.5
Nominal heat output		kW	18.3	30.7	63.8
Efficiency		%	88.8	88.2	88.0
Gas consumption <sup>(1)</sup>	natural gas	m <sup>3</sup> /h	2.18	3.68	7.67
	LPG G30	kg/h	1.62	2.72	5.72
	LPG G31	kg/h	1.59	2.69	5.61
Air flow <sup>(2)</sup>	with free outlet	m <sup>3</sup> /h	2900	4300	7600
	at maximum admissible pressure drop	m <sup>3</sup> /h	1600	3100	5800
Temperature rise	with free outlet	K	19	21	24.5
	at maximum admissible pressure drop	K	34	29	32
Available pressure head		Pa	110		
Gas connection		"M	1/2	1/2	3/4
Air inlet pipe diameter <sup>(3)</sup>		mm	130		
Exhaust air pipe diameter <sup>(3)</sup>		mm	110		
Electrical supply			230 V 1N - 50 Hz		
Installed wattage		W	600	620	920
Operating temperature range <sup>(4)</sup>		°C	0/35		
Weight		kg	66	82	133

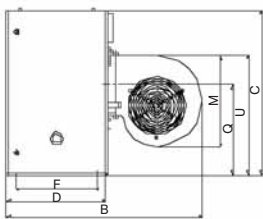

Right view

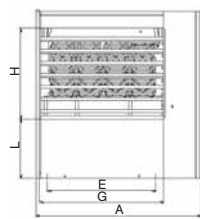

Frontal view

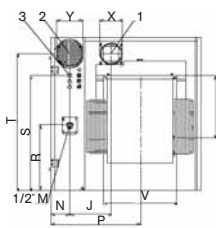

Back view M 20C - M 30C

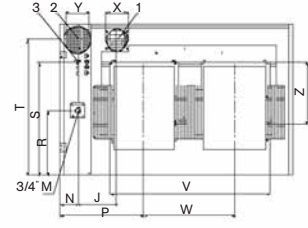

Back view M 60C

1 Flue

2 Air intake

3 Conduit entry for electrical connection

	A	B	C	D	E	F	G	H	J	L	M	N	P	Q	R	S	T	U	V	W	X	Y	Z
M 20C	630	915	800	490	370	405	440	430	215	285	393	95	390	435	340	600	715	563	340	--	113 <sup>(5)</sup>	135 <sup>(5)</sup>	300
M 30C	770	960	800	490	510	405	580	430	215	285	440	95	460	435	340	600	715	580	374	--	113 <sup>(5)</sup>	135 <sup>(5)</sup>	324
M 60C	1270	960	800	490	1010	405	1080	430	215	285	440	95	468	435	340	600	715	580	870	495	113 <sup>(5)</sup>	135 <sup>(5)</sup>	324

The M C heaters (fig. 1) could be supplied by the following accessories:

- mixing chamber kit (fig. 2);

- regulation damper;
- air filters;
- filter holder kit;
- antivibration joints;

- base frame;
  - support bracket.
- All these components can be installed on the back

or on the bottom side of the chamber (fig. 3).



Fig. 1

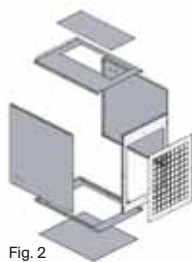

Fig. 2

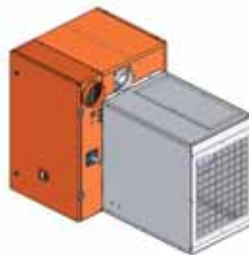

Fig. 3

<sup>(1)</sup> At 15 °C - 1013 mbar.

<sup>(2)</sup> At 20 °C - 1013 mbar.

<sup>(3)</sup> Nominal diameter of rigid pipe to be inserted into specific cylindrical housing.

<sup>(4)</sup> Indoor temperature of the installation location. The unit's internal components have been tested from 0 °C to 60 °C.

<sup>(5)</sup> External diameter.

Due to continuous product innovation and development, Robur reserves the right to change product specifications without prior notice.



To satisfy all norm requirements. Gas fired unit heaters for outdoor installation, with atmospheric burner, available in 3 models from 42.5 to 63.8 kW.

## M xt Series

### Distinguishing characteristics

- Heaters for **outdoor installation**, available in 3 models of heat output from 42.5 to 63.8 kW.
- External installation of the appliance allows air to be wholly or partially drawn from the outside, according to the requirements of the rooms.
- Automatic modulation of the flow of warm air into the heated environment, depending on air intake temperature, lowering it so that temperature is reduced.

All M xt heaters are supplied with:

- a remote control which incorporates the following functions of lock-out light, reset and summer-winter switches;
- kit with air inlet and exhaust pipes;
- plenum for weather protection;
- duct outlet flange suitable to be connected to an anti-vibration joint;
- control and safety devices suitable for external operation down to temperatures of  $-15^{\circ}\text{C}$ .
- M xt heaters with the **kit winter** can function when the external temperature drops till  $-40^{\circ}\text{C}$ .

### Ideal applications

The externally-installed M xt heaters are suitable for heating rooms:

- that need a constant ventilation (specific processes, public rooms etc.);
- where indoor installation is not permitted by norm (places of public entertainment or rooms where flames may form), such as repair shops, painting shops and joiner's shops.



		M 40xt	M 50xt	M 60xt	
Nominal heat input		kW	48.2	57.3	72.5
Nominal heat output		kW	42.5	50.7	63.8
Nominal gas consumption <sup>(1)</sup>	natural gas	m <sup>3</sup> /h	5.10	6.06	7.67
	LPG G30 / LPG G31	kg/h	3.80	4.52	5.72
Air flow <sup>(2)</sup>	nominal	m <sup>3</sup> /h	4200	5200	7800
	at maximum available pressure head	m <sup>3</sup> /h	2710	3350	4800
	reduced with unobstructed intake	m <sup>3</sup> /h	2940	3640	5,460
Maximum available pressure head		Pa	70	80	80
Temperature rise	nominal	K	28.4	27.3	23.0
	at maximum available pressure head	K	46.5	45	39.4
Gas connection		"M	1/2	3/4	3/4
Air inlet pipe diameter <sup>(3)</sup>		mm	130		
Exhaust air pipe diameter <sup>(3)</sup>		mm	110		
Electrical supply			230 V 1N - 50 Hz		
Installed wattage		W	400	640	900
Operating temperature range <sup>(4)</sup>		°C	-15/35		
Sound pressure level at 6 metres in free field at maximum airflow rate		dB(A)	46	46	48
Weight		kg	98	110	130

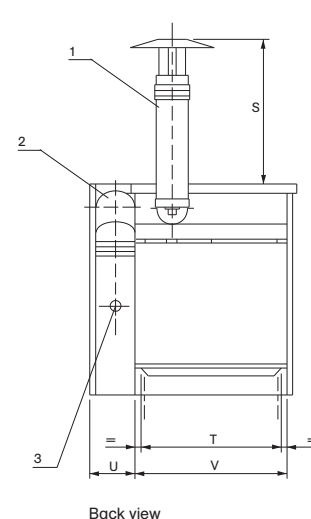
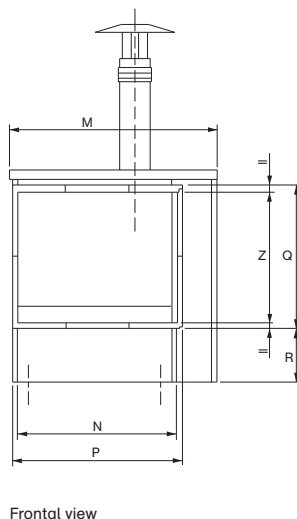
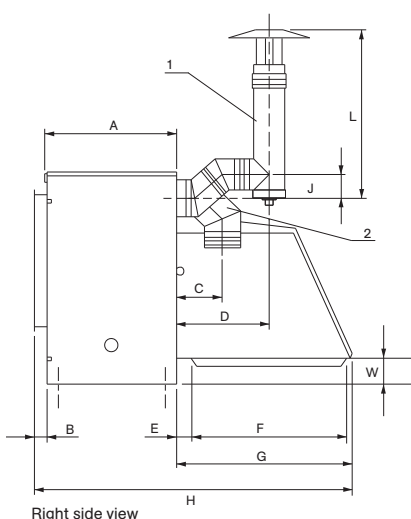

	A	B	C	D	E	F	G	H	J	L	M	N	P	Q	R	S	T	U	V	W	Z
M 40xt	500	50	175	350	51	602	684	1224	96	645	894	700	740	540	204.5	552	644	172	690	100	500
M 50xt	500	50	175	350	51	602	684	1224	96	645	1084	900	940	540	204.5	552	834	172	880	100	500
M 60xt	500	50	175	350	51	602	684	1224	96	645	1284	1100	1140	540	204.5	552	1034	172	1080	100	500

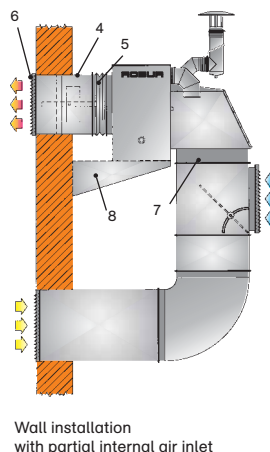
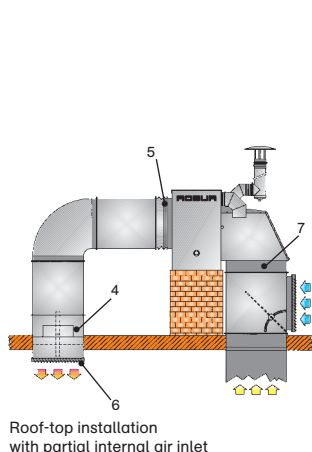
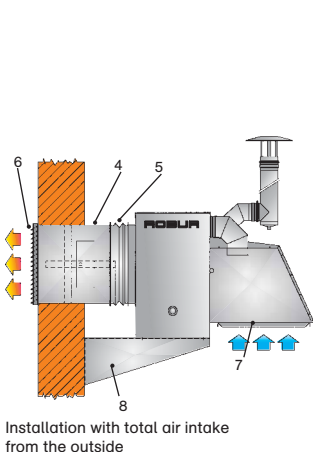

- 1 Exhaust outlet including terminal
- 2 Combustion air intake including bird protection net
- 3 Gas connection
- 4 Fire barrier
- 5 Anti-vibration joint
- 6 Air intake grille
- 7 Air intake filter
- 8 Support bracket kit for external installation.

<sup>(1)</sup> At 15 °C - 1013 mbar.

<sup>(2)</sup> At 20 °C - 1013 mbar.

<sup>(3)</sup> Nominal diameter of rigid pipe to be inserted into specific cylindrical housing.

<sup>(4)</sup> Indoor temperature of the installation location. The unit's internal components have been tested from -15 °C to 60 °C.

Due to continuous product innovation and development, Robur reserves the right to change product specification without prior notice.







## Accessories







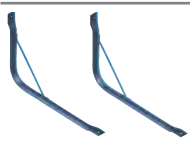
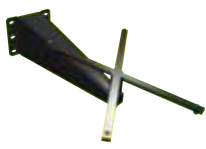
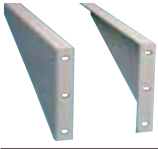

M heaters have a wealth of accessories to make them easy to use and to simplify and speed up installation.

### Standard accessories

	<b>Remote control box</b>	Remote control with reset button and lock-out warning lamp.
	<b>Kit winter</b>	The kit winter guarantees a good operation of the unit when the temperature drops below -40°C.

### Accessories, controls and flue components

	<b>Remote control</b>	Remote control with the following function: <ul style="list-style-type: none"> <li>• lock-out warning lamp;</li> <li>• reset button;</li> <li>• summer/winter switch</li> </ul>
	<b>Room thermostat</b>	Electromechanical thermostat with ON-OFF switch. Available also in IP 55 waterproof version.
	<b>Analogue programmable timer</b>	Equipped with a quartz programmable timer with mechanical switching and a thermostat with two independent control temperatures. Programming is on a weekly basis.
	<b>Integrated digital programmable timer</b>	A command that brings together all of the control and programming functions of the heater in a single device: programmable timer, electronic thermostat, summer/winter switch reset button and lock-out warning lamp. The command for the M 2v version also has a speed selector.
	<b>Pipes for separate exhaust outlet</b>	Additional flue and combustion air pipes may be added and are all available on request.
	<b>External terminal</b>	External stainless steel terminal, suitable for use with 110 - 130 mm (inlet and outlet air) diameter ducts with wall outlet.
	<b>Roof and wall concentric flue terminal kits</b>	A concentric terminal must be used for balanced flue applications. These are available for either roof or wall outlet.
	<b>Vertical louvres</b>	The louvres allow the airflow to be diffused in the desired direction, extending the air throw zone of the appliance, and also obstacles (such as columns, machine tools, etc.), for which direct heating is not appropriate, to be avoided.
	<b>Connector nozzle</b>	Connects the warm air inlet of the heater to the polyethylene pipe.
	<b>Polyethylene pipes</b>	Pipes of various diameters and lengths, to be connected to the connector nozzle.

	<p><b>Tubular support bracket for M and M 2v Types</b></p>	<p>Extremely easy to install, it is suitable for all models and is supplied with ties-rods, bolts and washers to anchor to the wall.</p>
	<p><b>Revolving wall support bracket for M and M 2v Types</b></p>	<p>This allows for an easy and correct installation of the gas unit heater. Complete with external counterplate.</p>
	<p><b>External support bracket kit for M xt</b></p>	<p>Manufactured specifically to be weather-resistant, it allows extremely easy installation of the appliance on the outside wall.</p>
<p><b>Antivibration joint for M C and M xt</b></p>		<p>To avoid vibration on warm air duct system.</p>
<p><b>Duct accessories for M C</b></p>		
	<p><b>Mixing chamber kit</b></p>	
	<p><b>Filter holder kit</b></p>	
	<p><b>Air filter G3 class</b></p>	
	<p><b>Regulation damper</b></p>	
	<p><b>Anti vibration joint</b></p>	
	<p><b>Base frame</b></p>	
<p><b>Duct accessories for M xt</b></p>		
	<p><b>Fire barrier for M xt</b></p>	<p>Galvanized steel casing. Clogger in fireproof material. Fusible, thermic circuit breaker and reset switch.</p>
	<p><b>Air inlet grid for M xt</b></p>	<p>Allows to spread the air flow in the desired direction</p>
<p><b>Safety microswitch for M xt fire damper</b></p>		<p>The microswitch controls the switch-off of the burner if the fire damper closes.</p>
<p><b>Air intake filter for M xt</b></p>		<p>In synthetic netting, washable on the mounting frame.</p>

**Note:** for the correct combination and specific means of use of the accessories, consult the specific technical documentation.

## Robur Pre-Sales Service

Provides design, technical and normative support to ensure the right choice and the most efficient use of Robur solutions.

T 035 888 111 [export@robur.it](mailto:export@robur.it)

## Robur Technical Support

A network of specialised service centres approved by Robur ensures effective, fast and safe support for pre-testing, commissioning and maintenance of the system.

T 035 888 111 [export@robur.it](mailto:export@robur.it)

Always close to  
our customers

## Robur produces



Hydronic heating systems with condensing absorption heat pump for heating and cooling. Available for geothermal systems too.



Absorption heat pumps, fired by gas and renewable energy for heating and cooling. Available for geothermal systems too.



Low electrical consumption gas fired absorption chillers and chiller-heaters for cooling, heating, refrigeration and process applications.



Gas fired condensing modular boilers for outdoor installation for heating.



Combined heating systems with gas fired boiler and air heater, including condensing systems, for installation sites under legislative restrictions.



Wall-mounted gas fired heaters, even condensing, for heating commercial and industrial spaces.



Evaporative air coolers ideal for medium-sized and large buildings.



Individual forced draught gas fired radiators for heating small and medium-sized spaces.



Air barriers to prevent thermal dissipation from doors of industrial buildings.



 **ROBUR®**  
caring for the environment

Robur Spa  
advanced heating  
and cooling technologies  
Via Parigi 4/6  
24040 Verdellino/Zingonia (Bg) Italy  
T +39 035 888111 F +39 035 4187114  
www.robur.com export@robur.it