



Catalogue, Operating and Installation Instructions

# Air Curtains

## *P Series*

***DoorMaster***

## Table of Contents



<b>Basic information</b> .....	<b>3</b>
Introduction .....	3
Operating Conditions and Arrangement .....	4
Design Description .....	4
Energy Savings .....	4
Installation .....	4
Marking .....	4
<b>Technical Parameters</b> .....	<b>5</b>
<b>New Air Curtain Planning</b> .....	<b>6</b>
Air Curtain Designing Nomogram .....	6
Designing Nomogram Glossary .....	7
Water Discharge .....	7
Air Curtain Control and Regulation .....	7
<b>VCP Control Unit</b> .....	<b>8</b>
<b>Connection Examples</b> .....	<b>9</b>
<b>Installation, Operation and Service</b> .....	<b>12</b>
Wiring and Safety .....	12
Commissioning .....	12
Wiring and Safety .....	12
Operation, Maintenance and Service .....	13
Operational Inspections .....	13
<b>Packaging, Spare Parts and Disposal</b> .....	<b>14</b>
Type Plate .....	14
Information and Safety Labels .....	14
Storage .....	14
Packaging .....	14
Disposal .....	14
Waste Specification .....	14

**Basic Information**

**Introduction**

DoorMaster air curtains create an invisible aerodynamic barrier to restrain free air flow between the indoor and outdoor environment, e.g. at the building entrance. The other integral function of the air curtain is the mixing of infiltrated air with heated air in the air curtain area, which reduces the negative chill factor caused by the cold air flow. If the air curtain is properly designed it will improve the indoor environment comfort while simultaneously reducing the building's operating expenses. Air curtains can process air without rough dust, grease, chemical vapours or other impurities. They are designed for normal environments (ČSN 33 2000-3; IEC 364-3/A1).

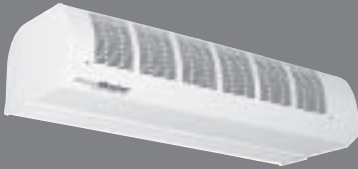
Use in aggressive, outdoor and humid / moisture condensing environments or explosive environments is forbidden! Electrically heated or unheated versions can be used at ambient temperatures as low as -5 °C (providing an environment without water condensation is ensured). The version with a water heater (W) is not equipped with antifreeze protection and therefore it may only be installed in non-freezing areas (+5°C to +40°C). Otherwise, a sufficient supply of hot water must be ensured to prevent the heat exchanger from freezing.

DoorMaster Comfort Air Curtains	<b>C1 Series</b>		<p><b>Length of the Air Curtain:</b></p> <p>1 m <input type="checkbox"/></p> <p>1,5 m <input type="checkbox"/></p> <p>2 m <input type="checkbox"/></p> <p><b>Recommended installation height:</b> 2,2 až 2,5 m*</p>	<p>For information on the C and D air curtain lines, refer to the publication "C1 and D2 Air Curtains"</p>	<ul style="list-style-type: none"> <li>■ Up-to-date design</li> <li>■ Silent operation</li> <li>■ High efficiency</li> <li>■ Low operating and maintenance costs</li> </ul>
	<b>D2 Series</b>		<p><b>Length of the Air Curtain:</b></p> <p>1 m <input type="checkbox"/></p> <p>1,5 m <input type="checkbox"/></p> <p>2 m <input type="checkbox"/></p> <p>2,5 m <input type="checkbox"/></p> <p><b>Recommended installation height:</b> 2,4 až 3,0 m*</p>	<p>Informace o clonách DoorMaster C a D naleznete v samostatné publikaci Vzduchové clony C1, D2</p>	<ul style="list-style-type: none"> <li>■ Low weight</li> <li>■ Easy control</li> <li>■ Long service life</li> <li>■ Favourable price</li> </ul>
DoorMaster Industry Air Curtains	<b>P Series</b>		<p><b>Length of the Air Curtain:</b></p> <p>2 m <input type="checkbox"/></p> <p>2,5 m <input type="checkbox"/></p> <p>3 m <input type="checkbox"/></p> <p>3,5 m <input type="checkbox"/></p> <p>4 m <input type="checkbox"/></p> <p><b>Recommended installation height:</b> 2,0 až 4,5 m*</p>		<ul style="list-style-type: none"> <li>■ Energy savings</li> <li>■ Low price</li> <li>■ Low operating and maintenance costs</li> <li>■ High efficiency</li> <li>■ Long service life</li> <li>■ Easy control</li> <li>■ Possibility to use in vertical position</li> <li>■ Short delivery time</li> </ul>

\* We recommend consulting the suitability of a given type of air curtain for a particular environment with the manufacturer or the air-handling device designer.

## Basic Information

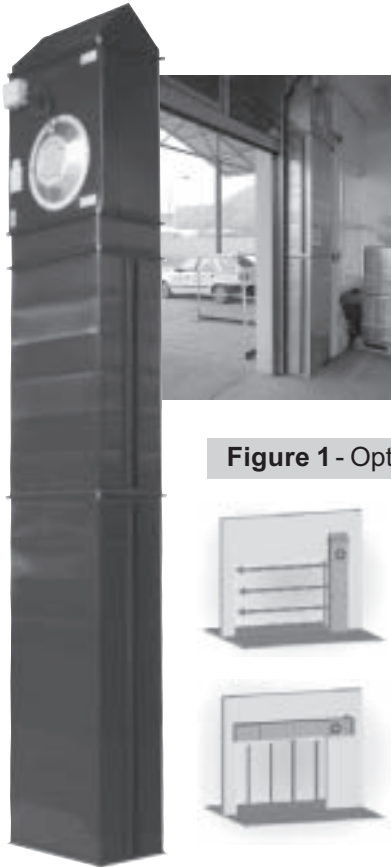
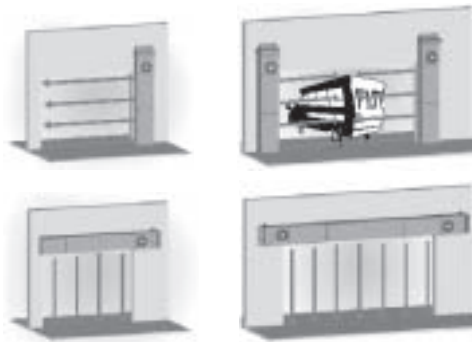

Figure 1 - Options of arrangement



### Operating conditions

Air curtains are designed for indoor installations (environment: normal, basic) above or next to the door (possibilities of their arrangements are shown in the figure above). They are suitable for all kinds of buildings where busier traffic of freight and manipulating means or persons going in and out of the building can be expected. Typical installation sites are production and industrial buildings, stores and transport terminals, gates for trucks, car services, garages, car washes, fairgrounds, markets, drying houses, etc. It is advisable to consult the suitability of a given type of air curtain for a particular environment with the manufacturer or the air-handling device designer.

### Construction Description

Air curtains are produced in four output rating lines, and the length of the exit slit is designed for the given door. As standard, the air curtain and its parts are made of galvanized sheets (Zn 275 g/m<sup>2</sup>) without colour coating finish. Optionally, the air curtain can be delivered finished with RAL 9002 (or other) baked enamel. The exit slit is fitted with directing fins.

DoorMaster P air curtains are equipped with a duct radial fan directly driven by the motor, a VMR inlet screen and an STB exit slit. The assembly of the air curtain can also be optionally equipped with an EU3 insert filter. The filter insert can be partially regenerated. Full regeneration of the filter insert can only be performed by replacing the filtrating textile. The air can be heated either by the Cu/Al finned water heater or electric heater.

### Energy savings

The high-pressure DoorMaster air curtains of the "P" series, developed by REMAK, provide more economical operation at a significantly lower price compared to competitive low-pressure air curtains. Operating costs, created especially by the air heating costs, are less than half compared to so-called "economy" or "energetically active" air curtains. This extraordinary economical operation of DoorMaster air curtains is based on their high-pressure concept. These air curtains feature a narrow exit slit which, in spite of having high pressure loss (hundreds of Pa) and which need the use of relatively high pressure fans due to high air flow velocity of 10 to 18 m/s, provide long reach of the air stream while **minimizing air flow rates**.

Common air curtains must be equipped with a 4 to 5 times wider exit slit (approx. 160 mm) compared to high-pressure air curtains. They work at a slightly lower air velocity but require 4 times higher air flow rates. The following table illustrates the above-mentioned relation comparing the heating inputs of common, economy and high-pressure air curtains per 1 m height of the air curtain stream.

Table 1 – Energy savings

Unit type	Slot	Speed	Airflow rate		Input	Ratio
	mm	m/s	m <sup>3</sup> /s	m <sup>3</sup> /h	kW	%
Regular	160	10	1,6	5760	39	100
Economic*	160	10	1,6	5760	19	50
Hi-pressure	35	12	0,42	1512	10	26

\* The so-called economy air curtain is sometimes identified as an "active" one. Heating power input is calculated for  $\Delta t = 20^{\circ}\text{C}$ .

### Installation

**Before installation, familiarize yourself with the Safety Rules on page 12.**

The air curtain is delivered disassembled. Individual elements of the air curtain can be connected together by means of bar flanges while keeping their prescribed order. Self-adhesive sealing must be applied between the flanges. The conductive interconnection of all air curtain parts must be ensured by the fan-shaped washers. The air curtain must be anchored to the wall or building structure so that its stability will be ensured. As standard, the air curtain is not fitted with any fixing elements.

### Type identification

The following picture describes type identification for accurate specification of DoorMaster P industrial air curtain units.

Figure 2 - Type marking

**P - 7 W - 300**

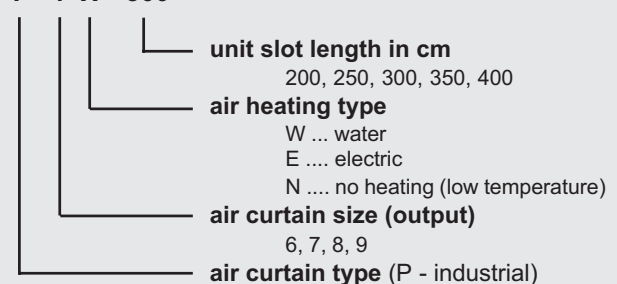

**Technical Parameters**

The following tables include important technical parameters of the produced air curtains arranged according to the type of air heating, i.e. water (W), electric (E) or without heating - a low temperature version (N).

The exit slit height can be ordered from 2 to 4 m. The reach range of the air stream changes depending on the selected exit slit height. The dimensioning of the exit slit can be done using a nomogram (page 6).

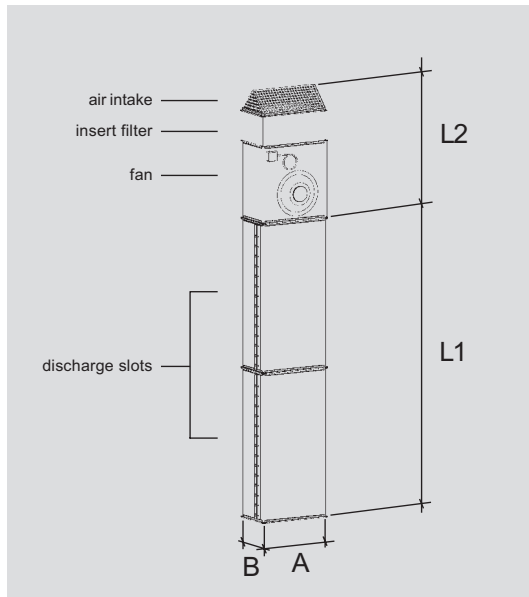

Water Heating(W)						
DoorMaster		type	P-6W-...	P-7W-...	P-8W-...	P-9W-...
Air stream reach range		m	<b>2,0 to 4,0</b>			
Max. air flow rate		m <sup>3</sup> /h	3900	5900	6100	8300
Max. air flow rate.		m <sup>3</sup> /s	1,08	1,64	1,69	2,31
Power supply			3 x 400 V / 50 Hz			
Max. total el. current		A	4,1	6	5,1	6,8
Max. total input		kW	2,5	3,5	2,8	3,8
Protection degree			IP 54			
Heating medium			water up to 110°C and 1.5 Mpa			
Heat exchanger connection			male thread G 1"			
Filtration class			G3			
Width	A	m	0,6	0,7	0,8	0,9
Depth	B	m	0,35	0,4	0,5	0,5
Exit slit length	L1	m	2,0 to 5,0			
Installation height	L2	m	1,47	1,58	1,74	1,84
Weight	m	kg	100	125	159	190

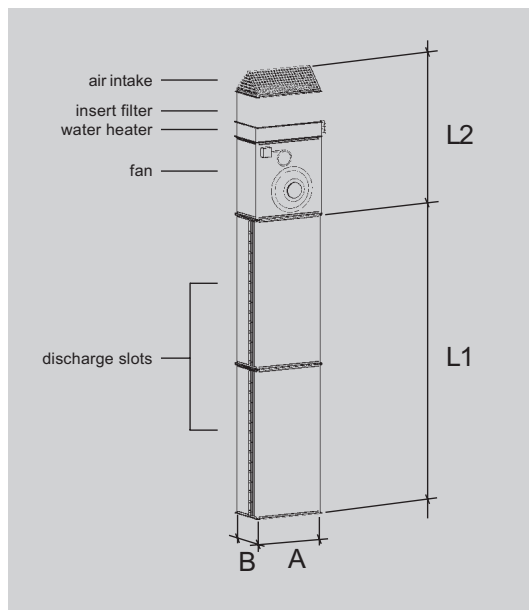

Electric Heating (E)						
DoorMaster		type	P-6E-...	P-7E-...	P-8E-...	P-9E-...
Air stream reach range		m	<b>2,0 to 4,0</b>			
Max. air flow rate		m <sup>3</sup> /h	3950	5950	6150	8350
Max. air flow rate.		m <sup>3</sup> /s	1,10	1,65	1,71	2,32
Power supply			3 x 400 V / 50 Hz			
Max. fan el. current		A	4,1	6,0	5,1	6,8
Heating el. current		A	34,1	45,5	45,5	45,5
Max. fan input		kW	2,5	3,5	2,8	3,8
Max. heating input		kW	22,5	30*	30*	30*
Protection degree			Fan IP 54, Heater IP 20			
Filtration class			G3			
Width	A	m	0,6	0,7	0,8	0,9
Depth	B	m	0,35	0,4	0,5	0,5
Exit slit length	L1	m	2,0 to 5,0			
Installation height	L2	m	1,92	2,18	2,34	2,44
Weight	m	kg	116	156	180	210

\* limited air heating efficiency

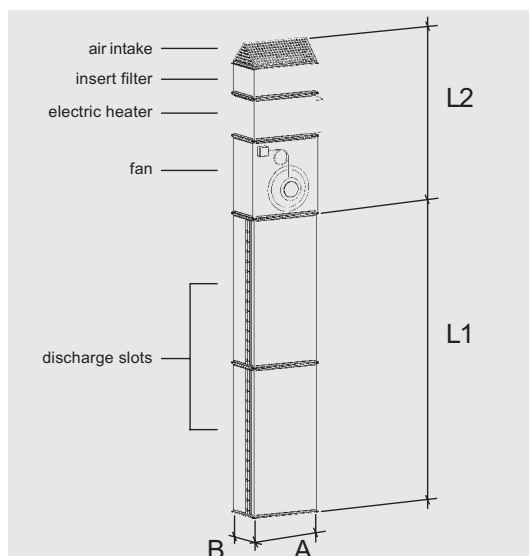

No Heating (N)						
DoorMaster		type	P-6N-...	P-7N-...	P-8N-...	P-9N-...
Air stream reach range		m	<b>2,0 to 4,0</b>			
Max. air flow rate		m <sup>3</sup> /h	4000	6000	6200	8400
Max. air flow rate.		m <sup>3</sup> /s	1,11	1,67	1,72	2,33
Power supply			3 x 400 V / 50 Hz			
Max. total el. current		A	4,1	6	5,1	6,8
Max. total input		kW	2,5	3,5	2,8	3,8
Protection degree			IP 54			
Filtration class			G3			
Width	A	m	0,6	0,7	0,8	0,9
Depth	B	m	0,35	0,4	0,5	0,5
Exit slit length	L1	m	2,0 to 5,0			
Installation height	L2	m	1,32	1,43	1,59	1,69
Mean weight	m	kg	81	110	128	157

## Air Curtain Designing Nomogram

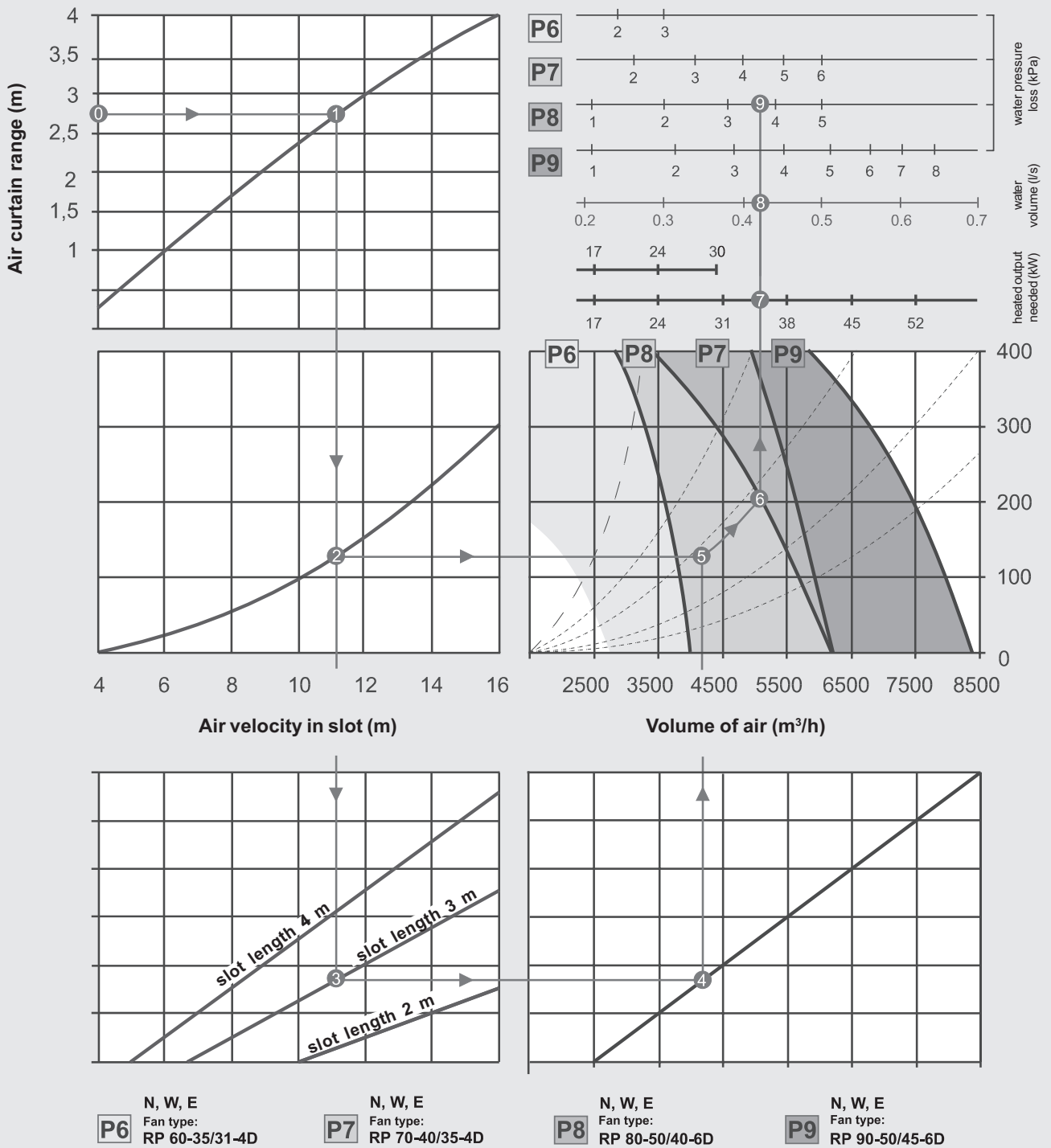

### Projecting procedure - detailed explanation of terms and projecting procedure is on page 7

- select type of heating (for instance water - W)
- select orientation and location of air curtain according to pic. 1 on page 4 (e.g. one-side unit on a side)
- select air curtain range ① (for instance 2,7 m which corresponds with gate width for the selected orientation)
- select operating conditions ① (for instance regular)
- draw a vertical line from point ② on the curve, which determines the discharge airflow velocity (for instance 11,6 m/s)
- select discharge slot length ③ (for instance 3 m, which corresponds to gate height for the selected orientation)
- draw a vertical line up from point ④ on the curve, which determines the minimum airflow rate needed (for instance 4.200 m³/s)
- draw a horizontal line from point ② on the curve, which determines the slot pressure drop (for instance 125 Pa)
- point of intersection of the lines in point ⑤ lies with some of the coloured fields (for instance in the green field)
- the coloured field, in which point ⑤ is located, determines the proper air curtain unit size (e.g. green colour → P-8W-300)
- parabolic prolongation to full curve demarcating the coloured field from the upper side will determine the real working point ⑥ of the air curtain
- the real (higher than the minimum needed) airflow (for instance 5.000 m³/s) corresponds to the real working point ⑥
- the necessary heating output ⑦ (for instance 35 kW) corresponds to the real airflow
- the necessary water flow rate ⑧ (for instance 0,42 l/s) corresponds to the heating output needed - applicable for water heated curtains and water drop of 90/70°C.
- the adequate water pressure drop ⑨ (for instance 3,7 kPa) to the necessary water flow of the selected curtain (P-8...)

**New Air Curtain Planning**

The nomogram and procedure for air curtain design is on page 6. On your request, the manufacturer will perform complete planning of the air curtain assembly. The input data and request form are on page 15.

**Designing Nomogram Glossary**

**Type of Air Heating**

It is necessary to determine the type of air heating in accordance with the installation conditions. Water heating (W) is the most convenient type of heating. If hot water is not available, then electric heating (E) can be used. If air heating is undesirable, then air curtains without heating (N) can be used; however, the efficiency of such air curtain is limited.

**Orientation and Arrangement of the Air Curtain**

The air curtain orientation must be selected in accordance with the door type. The air curtains for a section door are always installed on the door's sides. The air curtains for a wing door are always installed above the door. The single-sided air curtain arrangement will mostly do for door areas up to 10 m<sup>2</sup>. The double sided air curtain arrangement should always be selected for door areas above 12 m<sup>2</sup>, or if large objects (truck, palettes of goods, etc.) are required to be situated within the door area for a longer time. Another reason for using the double sided arrangement can be the need to divide the larger ground area of the single side air curtain into two smaller ones.

**Table 2 - orientation and arrangement**

Arrangement		Range	Slot length
one-side	side	gate width	gate height
	overhead	gate height	gate width
two-side	side	1/2 gate width	gate height
	overhead	gate height	1/2 gate width

**Reach Range and Length of the air curtain**

The reach range is the perpendicular distance from the exit slit where the air flow velocity is still at the minimum limit. The reach range and the air curtain length depend on its orientation and arrangement. The nomogram has been developed for standard working conditions.

**Standard Working Conditions**

- Premises with one door (separation of two indoor areas)
- Constant-pressure air handling within the premises.
- Without ram wind
- Intermittent and momentary door opening
- Building without "chimney effect"

**Non-standard Working Conditions**

- Over or under pressure within the premises
- Several doors (especially if they are situated on opposite sides)
- Frequently opened door
- Door open for longer times

These factors shift the nomogram selection curve to the right (point).

**Air Flow Velocity in the Exit Slit**

The air flow velocity in the exit slit depends on the required reach range of the air curtain and the selected working conditions. This parameter is only informative for the design procedure.

**Air Flow Rate (Quantity)**

First, the "minimum needed" air flow rate (point ) is determined using the designing nomogram. This air flow rate is given by the minimum outlet air flow velocity and the exit slit area. However, the actual air flow rate corresponding to the air curtain fan (point ) will be significantly higher, and it will lie on the intersection of the parabola going through point , and the solid curve enclosing the upper side of the respective coloured field.

**Necessary Heating Output**

The necessary heating output is derived from the actual airflow rate at  $\Delta t = 20^{\circ}\text{C}$ . The output of electric heaters can be 22 kW or 30 kW while controlled by the control unit. The output of the water heater is given by the heating water quantity (discharge); its discharge must be ensured by the pump. This parameter is irrelevant for the low temperature air curtain (without heating).

**Water Discharge**

The heating water discharge is an important parameter for the water-heated air curtains; the heating water discharge is constant during the air curtain operation. In most cases, there is no need for further control of the heater output than just switching the pump on and off. The nomogram has been created for a temperature gradient of 90/70°C. If the air curtain processes only circulating air and the room temperature does not drop below +5°C, antifreeze protection will not be necessary.

This parameter is irrelevant for low temperature (N) and electric (E) air curtains.

**Heating Water Pressure Loss**

The heating water pressure loss for the respective water heater and heating water discharge is included in the nomogram. The total pump delivery head is calculated by adding the piping pressure loss to the heater pressure loss. This parameter is irrelevant for low temperature (N) and electric (E) air curtains.

**Table 3 - Air control**

Air heating	control unit	Connection
no heating (N)	STD	A
water (W)	VCP-W	B
electric (E)	VCP-E	C

**Air Curtain Control and Regulation**

VPC control units (resp. STD relays) can be used to control, regulate, supply and protect the air curtains. The type of prescribed controller according to the used heating system is included in the following table.

DoorMaster "P" air curtains may only be connected to prescribed controller types. Other ways of protection (control) are not allowed concerning the warranty conditions. For wiring diagrams of the A, B and C controllers, refer to pages 9 to 11. For a description of controllers, see page 8.

## VCP Control Unit

### VCP control units

#### Operating conditions, position and location

VCP-series control units are designed for interior use in dust-free and dry environments without chemicals. They are designed according to recommendation of IEC 33 2000-3, enclosure NM, table 32-NM1 for regular effect classes. At the same time they meet the requirements of Czech standard ČSN 33 0300, article 3.1.1 - basic environment. Protection class of plastic box is IP 54 in case of closed door and IP 40 in case of opened door. The control units can be mounted directly on surfaces of combustible class of A and B according to of Czech standard ČSN 73 0823. Permissible ambient temperature is from +5 to 40°C. The units are fixed in vertical position either directly on the wall or they are flushmounted 50 mm under the plaster. The cables can be led through plastic troughs or under the plaster. The unit has to be positioned taking into consideration easy access of operators and cable connections.

In case of VCP-E units it is necessary to secure sufficient protection of the lead-in wires so that the residual over-voltage level would not exceed 1,2 kV.

#### Construction and materials

All types of VCP control units are built into plastic boxes with transparent front door behind which the control elements are located. The outer dimensions of the plastic box are 275 x 370 x 140 mm. The power section consists of input terminal board for connection of supply cable, circuit breakers, contactors and of terminal boards for connection of the particular elements of the air curtain unit. Plastics, copper, aluminium and zinc-coated metal sheets are used in the inner construction. Components inside the unit are fitted on DIN strips or on printed connection boards.

#### Control and protection

Fan protection against overheating is secured by fitting the fan coils with thermocontacts that will disconnect

the protective circuit when the marginal temperature is exceeded. It will make the control unit disconnect the fan lead-in wires from power supply. After the coils are cooled down and the thermocontacts are switched on, the air curtain unit fan will not be auto-matically switched on. The unit can be started by operator after finding out the cause and repairing the defect. Easy and simple control is an advantage of VCP control units.

#### Start and stop

The gate air curtain unit is started and stopped by a switch on the front panel of control unit marked **START - AUTO**. Permanent operation of the unit in manual mode can be adjusted by switching the switch over to the **START** position and the unit operation is indicated by switch control light. Switching the switch over to **AUTO** position, the mode of automatic operation switching by 250V / 0,5 A external potential-free contact will be set. This contact is to be connected to the control unit terminals. If the contact is not connected, the unit is switched off in **AUTO** position. Electric heated air curtain units have the safety run-out of the fans secured until the moment the temperature in electric heater chamber drops. Definitive air curtain unit stop (for instance seasonal) is made by switching the main switch off.

By **HEATER DISCONNECTING SWITCH** (VCP-E) is it possible to disconnect manually the electric heater control. The red control light on this switch indicates switching the heater on. Temperature of discharge air of the air curtain unit is set by thermostat upon putting the unit into operation. By **PUMP DISCONNECTING** (VCP-W) we can disconnect the hot water pump switching, which is otherwise switched on simultaneously with unit starting. If a defect occurs on fan or electric heater in operation of the gate air curtain unit, the control unit will stop unit automatically. After removing the defect, it is necessary to reactivate the circuit breakers. Then the unit can be re-started.

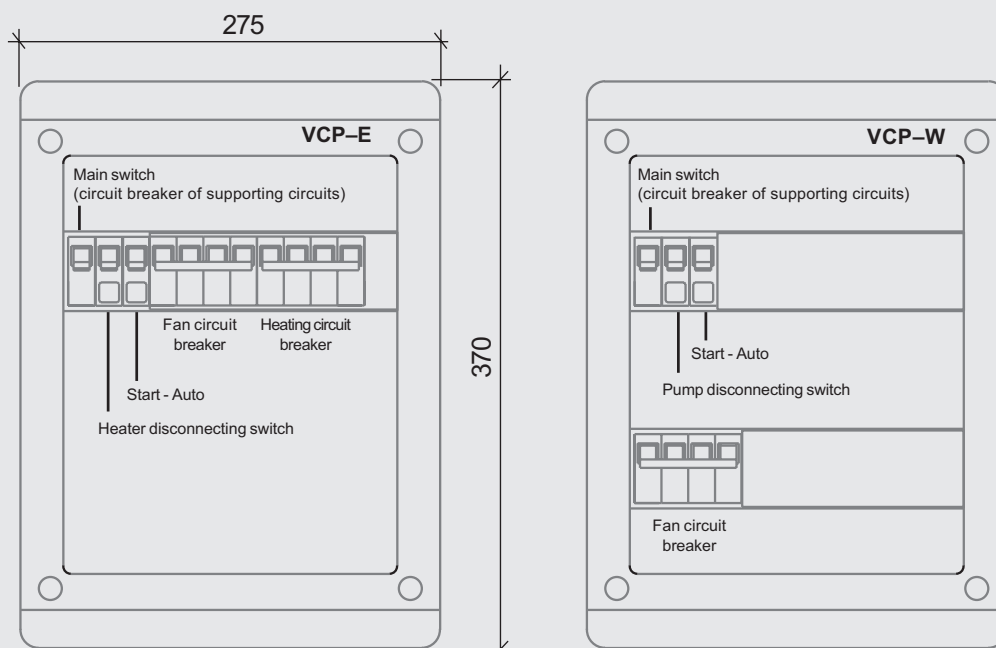

Connection Examples

A

Connection of low temperature unit without heating (N)

Figure 3 shows the connection of the low temperature air curtain (i.e. without air heating). Protective STD relay ensures the start and stop of the air curtain and overloading protection of the fan motor. The protective relay will automatically switch the fan motor off if the maximum permissible motor winding temperature of 130°C is exceeded. The protective relay is equipped with a restart button (RESET). The air curtain can be manually controlled by the switch situated on the STD relay. If switching of the air curtain by an external contact connected to the door opening mechanism is required, the contactor must be inserted in front of the protective relay (if the power supply fails, the fan will be automatically switched on by the circuit breaker after the power supply is resumed). The STD relay is designed for indoor and outdoor use in a chemical-free and non-explosive environment. Degree of protection is IP54. Maximum permissible ambient temperature ranges from -25°C to +40°C. The protective relay is enclosed in a plastic casing which can be mounted directly on a wall, or partly embedded into plaster. The protective relay can also be installed without the plastic casing on the DIN bar inside the control unit.

Observe the rules on page 12.

Figure 3

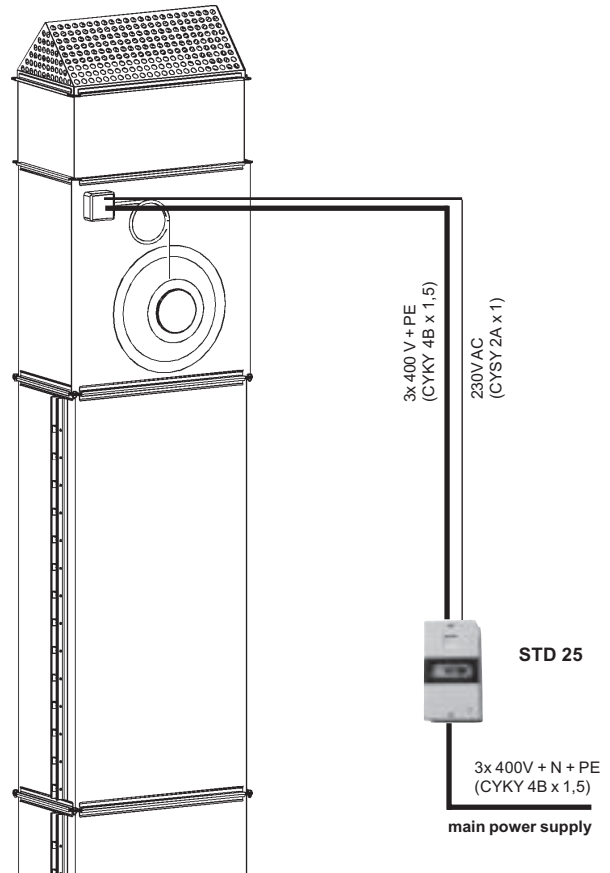
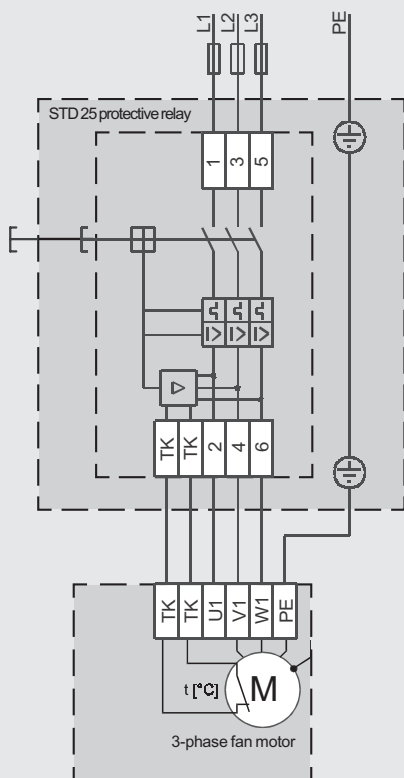

Figure 4



STD 25 protective relay

STD 25 technical parameters		
Nominal voltage	U	3x 400V, 50 Hz
Minimum voltage	U <sub>min</sub>	60 V
Maximum voltage	U <sub>max</sub>	400 V
Minimum current	I <sub>min</sub>	0,45 A
Maximum current	I <sub>max</sub>	25 A
Dimensions	WxHxD	78 x 140 x 93
Weight	m	0,6 kg

## Connection Examples

### B

#### Connection of water heated unit (W)

Figure 5 shows the connection of the water-heated air curtain to the VCP-W control unit. The control unit ensures start and stop of the air curtain and overloading protection of the fan motor. Further, it provides pump protection. The switching of the pump is related to the air curtain operation. During the summer season, the pump can be taken out of operation by switching the pump trip switch off. The water heating system is not equipped with antifreeze protection and therefore it may only be installed in non-freezing areas where the temperature does not fall below +5°C. The air curtain can be controlled either by the switch situated on the front panel of the control unit or by an external contact connected to the door opening mechanism; then the air curtain is automatically started/stopped in relation to the door opening/closing. For control of simple applications, an STD relay can be used which simultaneously ensures overload protection of the fan motor. In such case, the pump supply and protection must be ensured separately. The water-heated air curtains have no outlet air temperature control.

**Observe the rules on page 12.**

Figure 5

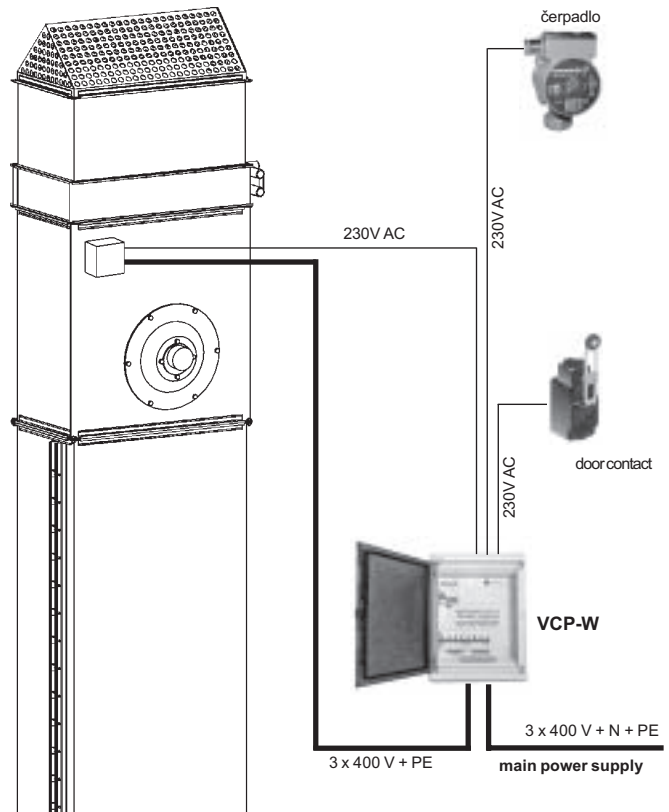
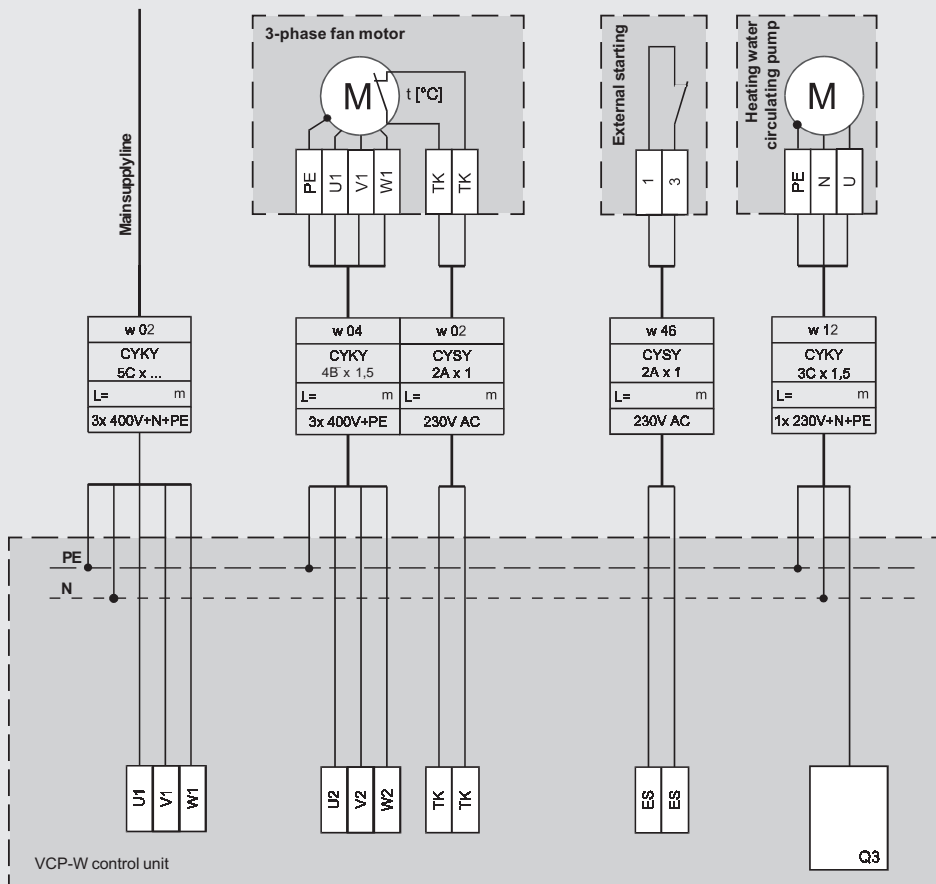

Figure 6



Connection Examples

C

Connection of electric heated unit (E)

Figure 7 shows the connection of the electrically-heated air curtain equipped with outlet air temperature control to the VCP-E control unit. The control unit ensures start and stop of the air curtain and overload protection of the fan motor and protection of the electric heater against overheating. The electric heater is equipped with double independent thermal protection which ensures overheating protection in cooperation with the VCP-E control unit. The air curtain can be controlled either by the switch situated on the front panel of the control unit or by an external contact connected to the door opening mechanism; then the air curtain is automatically started (stopped) in relation to the door opening (closing) - however, the heater's temperature rise time must be taken into account. The control unit ensures safe stop of the air curtain with an electric heater by the rundown of the fan until the electric heater chamber is cooled down. The two-stage control of the outlet air temperature is carried out in relation to the signal from the control thermostat (accessory) which is situated in the exit slit duct behind the fan. The thermostat stem must be placed in the air stream

Observe the rules on page 12.

Figure 7

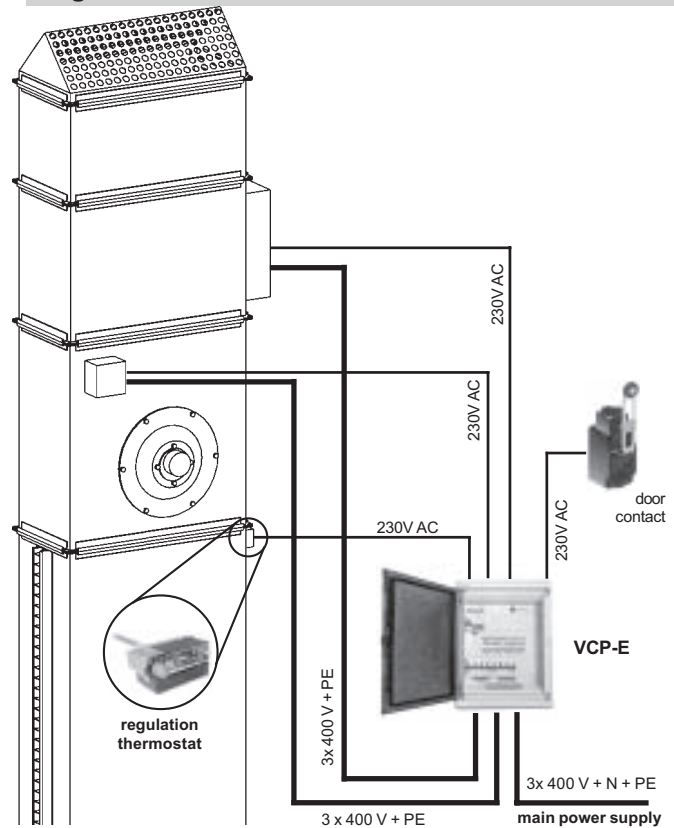
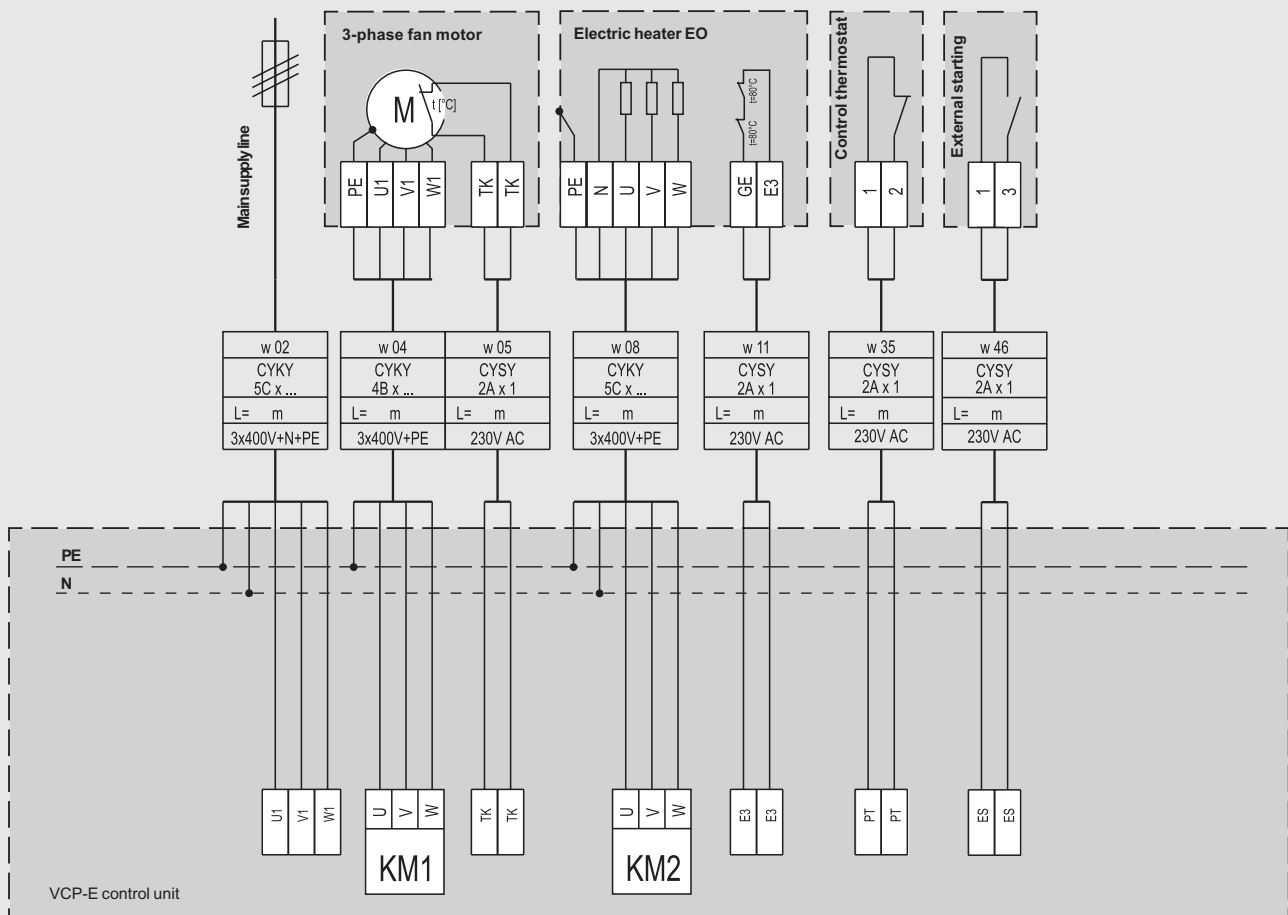

Figure 8



## Installation, Operation and Service

### Wiring and Safety

When handling, installing, wiring, commissioning, repairing or servicing the air curtains, it is necessary to observe valid safety rules, standards and generally recognized technical rules. Every device connection must comply with the respective safety standards.

- The wiring can only be performed by a worker licensed in accordance with the local legal regulations (ČÚBP č. 50/78 Sb., §6). An inspection of the wiring must be performed before commissioning.

- VCP control units can be connected to the TNS system (3x 400V+N+PE). PE and N terminals are independently brought out on the control unit inputs. The sizes of the input trip switches are given by the motor configuration, respectively by the size of the electric heater. However, we recommend verifying the switching capabilities of protective elements concerning the desired disconnecting time, overloading of the supply cable, short-circuit resistance and overloading of the supply cable.

- VCP control units can be connected to the air curtain via a cable system in accordance with the wiring and M&C project documentation.

- **The air curtain is supplied with power from the parent distribution board through the circuit breaker. The size of the circuit breaker is determined by the designer according to the local conditions and a connecting device. The air curtain must be provided with a lockable main switch of red colour on a yellow base. These elements are not included in the air curtain delivery. The power supply is connected to the terminals of the terminal box X1.**

**Other power cables (fan motors, electric heater) are connected to the terminals of the terminal box X2 situated in the bottom part of the control unit, and directly to the contactor terminals KM1, KM2 (version VCP-E). The cables of the 230V AC control circuits are connected to terminal box X3.**

- **It is essential to pay attention to the connection of the thermo contacts. The thermo contacts of the fan must always be connected only to the TK terminals; otherwise, there are risks of short circuit and thermo contact destruction.**

- Connecting cables can be led in under plaster or using cable trays but plastic cable trenches are the best. To satisfy the EMC needs, it is advisable to lead the signal cables separately from the power cables, and the main supply to the control unit must be provided with suitable over-voltage protection.

- **The protection against dangerous contact of non-live parts is performed by automatic disconnection of the power supply combined with additional interconnection of non-live parts of the air curtain in accordance with the ČSN 332000-4-41 standard.**

- Self-adhesive sealing must be applied between the flanges. The conductive interconnection of all air curtain parts must be ensured by fan-shaped washers.

- **All non-conducting parts (e.g. elastic connecti-**

**ons) must be bridged with yellow-green cables or plated copper cords of min. section 4 mm<sup>2</sup>, provided with cable tags and fan-shaped washers.**

- **The entire air curtain assembly must be interconnected with the VCP control unit by a separate yellow-green cable with section area corresponding to the section area of the main supply conductors, min. 4 mm<sup>2</sup> and larger. This cable is connected to the PE terminal on the control unit. The additional interconnection of the air-handling assembly must be connected to the protective terminal of the control unit in accordance with ČSN 332000-4-41, table 41NN.**

- The air curtain must be anchored to the wall or building structure so that its stability will be ensured.

- When mounting the control unit on a wall, commissioning it or during common operation, make sure you keep the control unit interior clean. The control unit contains sensitive electro-mechanical parts and being contaminated with dirt from a construction site (dust, sand, plaster, etc) it can endanger the safe operation of the entire device.

**It is essential to pay attention to the connection of the thermo contacts. The thermo contacts of the fan must always be connected only to the TK terminals; otherwise, there are risks of short circuit and thermo contact destruction.**

### Commissioning

- All the following check and service steps must be performed before air curtain commissioning.

- Before putting the device into operation for the first time, it is necessary to check the completeness of the air curtain and the proper fitting of all its parts. In particular, the completeness, locations and connecting of thermal sensors, fan and heater thermo-contacts and protective thermostats must be checked.

- The proper installation of fans and heaters must also be checked (the arrow indicates the air flow direction).

- **Special attention must be paid to conductive interconnection of all parts of the air-handling duct and other related devices.**

- The lines connected to the failure inputs must be checked. The lines must not be short-circuited or broken. Before starting the air curtain, it is necessary to verify the air curtain's response to individual failure inputs.

- Voltages of all three phases must be checked.

- The correct direction of the impeller rotation must be checked following the direction of the arrow on the fan cap. To do so, remove the rubber plug from the inspection opening in the fan cup. The direction of the air flow is not decisive.

- The rated currents (from the type plate) of every connected device must be measured after putting the air curtain into operation. These values must not exceed the maximum allowed limits

**Installation, Operation and Service**

**Operation, Maintenance and Service**

The air curtain must be kept in an operable condition. Guarantee or after-sale service is provided by the manufacturer or authorized regional service shops.

**Air Curtain Operation Safety Rules**

- Proper assembly, installation and commissioning are conditions for faultless and safe operation of the air curtain, as well as proper attendance by qualified operating staff.
- The installation and commissioning may be performed only by qualified personnel or by an authorized service technician.
- Only personnel who have been provably trained by the purchaser (manufacturer or authorized service technician) and warned of possible risks and hazards can operate the VCP control unit.
- The removal, bypassing or disconnecting of safety equipment and functions, or protective devices, is forbidden.
- Only faultless air-handling components can be used. Failures which can affect device safety must be removed immediately.
- **All precautions concerning electrical accidents must be strictly observed. Any actions restricting safety and/or protective precautions, even temporarily, must be strictly avoided.**
- **By no means may any guards or other safety equipment be removed. The device and its components may not be operated if safety devices or precautions are ineffective, or if their functioning is restricted.**
- **Before opening the door of the switch board, disconnect the power supply by means of the main switch. Never work on an energized device. Use protective work aids.**
- **When replacing fuses, the voltage-free state of the control unit must be ensured and only prescribed fuses and protective elements can be used.**
- **The harmful effects of electromagnetic emissions and overvoltage on signal, control, and power cables, which could cause dangerous unwanted actions or destroy electronic elements, must be avoided.**
- The sound power level (A) emitted by the device can reach 72 to 101 dB in relation to the exit slit length and the system regulation. The complete characteristics of the fans used, including acoustic data, are available from the manufacturer.
- Individual components of the air curtain can only be installed in accordance with the installation instructions.
- After failures like short circuits have been removed, always check the function of the automatic protective elements and verify the condition of the grounding interconnection.
- Only authorized personnel are allowed to recognize and remove failures, and put the device into operation. The same applies to work inside the switchboard (e.g. testing, replacing fuses). The manufacturer is not responsible for any damage resulting from using procedures other

than those specified in this documentation, and the one who it bears the risk of such use.

- The thermo contacts can cause a failure by disconnecting the protective circuits of the fan or electric heater. If this is the case, the under-voltage triggers of the circuit breakers are activated, disconnecting the power supply to these elements of the air curtain.
- Keep the documentation for further use. The installation and operating documentation must be available for the operating and servicing staff. It is advisable to store this documentation close to the air curtain.

**Operational Inspections**

The user must perform regular inspections of the electrical equipment at the prescribed intervals during the whole service life of the air curtain in accordance with the respective legal regulations.



**Important note:** If the heat exchanger is taken out of operating for the winter season, the water must be fully drained, e.g. by air blowing, or the heat exchanger system must be filled with antifreeze glycol solution. Otherwise, the water residue could freeze and break the copper pipes. Depending on the operating conditions, we recommend checking the filter insert one or twice a year. A fouled filter must be replaced.

**Type Plate**

Each fan unit of the air curtain is provided with a type plate with the following data:

- Manufacturer and its address
- CE, GOST Compatibility Declaration
- Type marking
- Production code
- Production date
- Production number
- Fan parameters

Figure 9 - Type plate

  	
<b>Ventilátor</b>	<b>RP 80-50/40-4D</b>
Výrobní kód	VRP0080504D
Datum výroby	29.08.2005
<b>Výrobní číslo</b>	<b>127192</b>
Objem	0,43 m³
Hmotnost	75 kg
Nominální průtok vzduchu	4200 m³/h
Statický tlak	576 Pa
Celkový tlak	261 Pa
Elektrický příkon	2957 W
Prúd	5,07 A
Čistý výkon ventilátoru	1412 W
Nominální napětí	3 x 400 / 50 V / Hz
Elektrický příkon max.	4919 W
Příčný proud max.	8,10 A
Průtok vzduchu max.	6631 m³/h
Celkový tlak max.	1040 Pa
Statický tlak min.	663 Pa
Pracovní teplota max.	40 °C
Počet polů	4
Termokontakty	Ano
Klíč	IP 54
Třída izolace	F
Typ regulace	napřevod
Počet regulačních stupňů	5

## Installation, Operation and Service

### Information and Safety Labels

- "Beware! Electrical device!" - Labels on the safety guards of the electrical equipment.
- Heating water inlet and outlet (version W).
- The label with the white arrow in the blue field indicates the direction of the fan's impeller rotation.
- The label with the blue arrow in the white field indicates the air flow direction.
- Labels with a symbol describing a particular function.

### Storage

It is necessary to maintain the permissible storage conditions for the standard device packaging in accordance with ČSN EN 60721-3-1: IE11 (+5°C to +40°C, max. humidity of 85 %, without water condensation or frost).

### Packaging

The individual parts are delivered in pallets covered with PE foil.

### Transport and Handling

During installation, respect the weight of individual parts. If necessary, use suitable lifting devices of sufficient loading capacity.

Do not lift the parts above persons. When installing the air curtain, take care not to damage the device parts.

Do not remove the protecting packaging until installation. Dispose of the packaging material in accordance with national waste disposal regulations.

### Accessories

Stainless connecting hose (only "W" air curtains) .....	G 1"-350
Protective relay for low-temperature air curtain without heating .....	STD controller
Air curtain with water heating .....	VCP-W control unit
Air curtain with electric heating .....	VCP-E control unit
Pump .....	UPS 25-40
Pump .....	UPS 25-60
Pump .....	UPS 25-80

### Spare Parts

Spare parts are not a part of the air curtain delivery. If needed, they can be ordered from REMAK a.s.

Spare filter inserts:

- P 6 air curtain filter VF3N 60-35
- P 7 air curtain filter VF3N 70-40
- P 8 air curtain filter VF3N 80-50
- P 9 air curtain filter VF3N 90-50

### Disposal

During the air curtain operation, it is necessary to ensure safe and environmentally-friendly disposal of all replaced parts, operating and auxiliary materials. When disposing of components and materials, it is necessary

to observe the respective national environmental protection and waste disposal regulations. In case of final device liquidation, it is necessary to follow the policy of sorted waste disposal. It is recommended to contact specialized providers that are involved in the waste business and ensure material disposal in accordance with local standards and regulations. We recommend metal parts be scrapped and other parts be disposed of in accordance with sorted waste regulations.

After exceeding its service life limit, the unit belongs to waste group Q14 according to the Waste Act (č. 185/2001 Sb.)

The unit contains metal parts, insulating and filtrating materials and electronic parts.

### Waste classification

(in accordance with Directive No. 381/2001 Sb.)

#### Used packaging:

- 15 01 02  
*(plastic packaging)*
- 15 01 03 paleta  
*(wooden packaging)*

#### Disabled device and its parts:

- 16 02 06 metal parts  
*(other items from disabled devices)*
- 15 02 03 filtrating materials
- 16 02 15 electric parts  
*(dangerous items from disabled devices)*

Printing and language mistakes are reserved.

These Installation and Operating Instructions (as a whole or a part) must not be printed or copied without prior written permission from REMAK a. s., Zuberská 2601, Rožnov pod Radhoštěm, Czech Republic. These Installation and Operating Instructions are the sole property of REMAK a. s. Changes reserved. Issued: 17th October, 2007

**Specify the contract:** .....

The yellow field contains the input data for air curtain unit designing

Company .....	Gate width [m] .....
Name - Surname .....	Gate height [m] .....
Street .....	Head height [m] .....
Postal code - town .....	Air heating type .....
Telephone .....	Water temp. drop* [°C] .....
Facsimile .....	
E-mail .....	Air curtain dispositions side / overhead
Project name .....	Operating conditions standard / non-standard

\* for water heated air curtain unit (W) only, \*\* see page 7

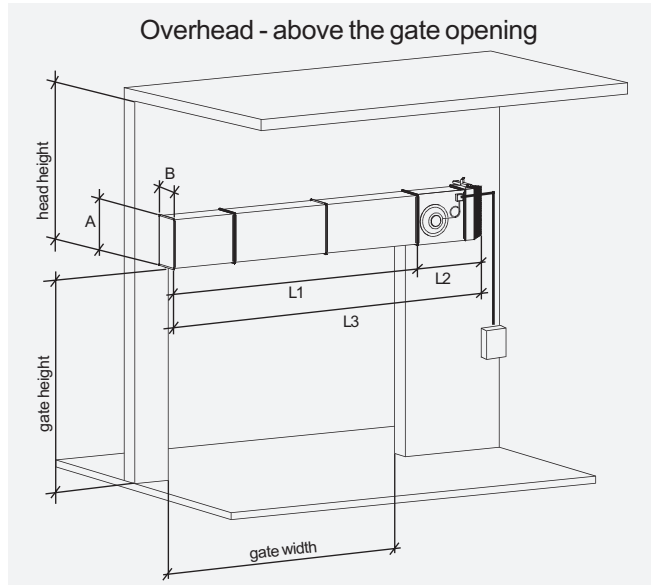
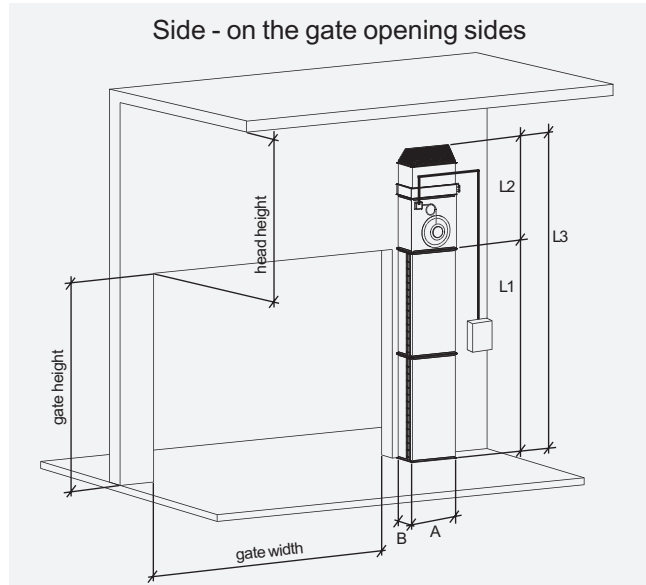

Price

DoorMaster	type		
Controller	type		
Accessory			
<b>Dimensions, weights, outputs</b>			
Air curtain reach		m	
Slot length	L1	m	
Height to built in	L2	m	
Width	L3	m	
Total height	A	m	
Depth	B	m	
Weight		kg	
Airflow rate		m <sup>3</sup> /h	
Power supply			
Electric protection			
Filtration class			
<b>Air curtain fan</b>			
Current		A	
Power input		W	
<b>Air curtain heater</b>			
Heating type			
Current		A	
Power input		kW	
Power output		kW	
Water temperature drop		°C	
Water flow rate		l/s	
Water pressure loss		kPa	
Connection			

.....  
Date:

.....  
Offer made by:



REMAK a.s.  
Zuberská 2601  
756 61 Rožnov pod Radhoštěm  
Česká republika  
tel.: +420 571 877 778  
fax: +420 571 877 777  
[www.remak.eu](http://www.remak.eu)